

# Service Manual

## Washer extractor

**W555H**

**Type W.55.H**



PLATON SERVICE  
8 (800) 500-34-47  
www.platonservice.com



**Electrolux**



**PLATON**SERVICE

8 (800) 500-34-47

[www.platonservice.com](http://www.platonservice.com)

# Contents

## Contents

1	Symbols .....	5
2	Technical data .....	5
2.1	Drawing .....	5
2.2	Technical data .....	6
2.3	Connections .....	6
3	Machine presentation .....	6
4	Function check .....	7
5	Door and door lock .....	8
5.1	Door lock .....	8
5.2	Door handle .....	10
5.2.1	Replacement of door handle .....	10
5.3	Problems and solutions .....	10
5.3.1	Door knob creating noise or feeling loose .....	10
6	Motor and motor control .....	11
6.1	Motor control unit .....	11
6.2	Replacement of motor .....	11
6.3	Replacement of the belt .....	13
7	Heating .....	14
7.1	Replacement of heating element .....	14
8	Drum .....	15
8.1	Replacement of drum .....	15
9	Drain .....	19
9.1	Drain valve .....	19
9.2	Drain pump .....	21
10	Detergent container .....	22
10.1	Replacement of detergent container .....	22
10.2	Replacement of siphon .....	23
10.3	Replacement of reed switch .....	23
11	Control panel .....	24
11.1	Control system .....	24
11.1.1	Description .....	24
11.1.2	Connections .....	25
11.1.3	Replacement of control system CPU .....	26
11.2	Control knob .....	31
11.2.1	Replacement of control knob .....	31
11.3	USB connection .....	33
12	I/O modules .....	33
12.1	General .....	33
12.2	Replacement of I/O module .....	34
12.3	External connections to I/O module type 2 .....	38
12.4	Circuit diagram of function options for I/O module type 2 .....	39
12.4.1	External coin meter/Central payment (2A) .....	39
12.4.2	Central payment (2B) .....	40
12.4.3	Central payment (2C) .....	41
12.4.4	Outputs for detergent signals and inputs for pause signals, "empty" signal and price reduction (2D) .....	42
12.4.5	Outputs for detergent signals and inputs for pause signals and "empty" signal (2E) .....	42
12.4.6	Central booking/payment (2F) .....	43
12.4.7	Machines with I/O module type 3 .....	44
13	Troubleshooting .....	44
13.1	General .....	44
13.2	Error code .....	46
13.3	Description of error codes and causes .....	50
	MAIN COMMON .....	50
	MAIN WASHER .....	51
	MAIN DRYER .....	56
	MAIN BARRIER .....	62
	MAIN W&D .....	65
	MAIN DRYER .....	66
	DRUM MOTOR COMMON .....	67

# Contents

---

DRUM MOTOR EWD .....	68
DRUM MOTOR KEB .....	72
DRUM MOTOR OBIWAN .....	81
FAN MOTOR COMMON .....	84
INTERNAL COM. ....	85
INTERNAL COM. I/O TYPE 10 .....	87
INTERNAL COM. I/O TYPE 6 .....	89
EXTERNAL COM. PAYMENT .....	89
EXTERNAL COM. CMIS .....	90
INTERNAL .....	91
14 Maintenance .....	92
14.1 Inspect the interior of the machine .....	92

The manufacturer reserves the right to make changes to design and component specifications.





**PLATON SERVICE**

8 (800) 500-34-41

[www.platonservice.com](http://www.platonservice.com)

## 1 Symbols

	Caution
	Caution, hot surface
	Read the instructions before using the machine

## 2 Technical data

### 2.1 Drawing

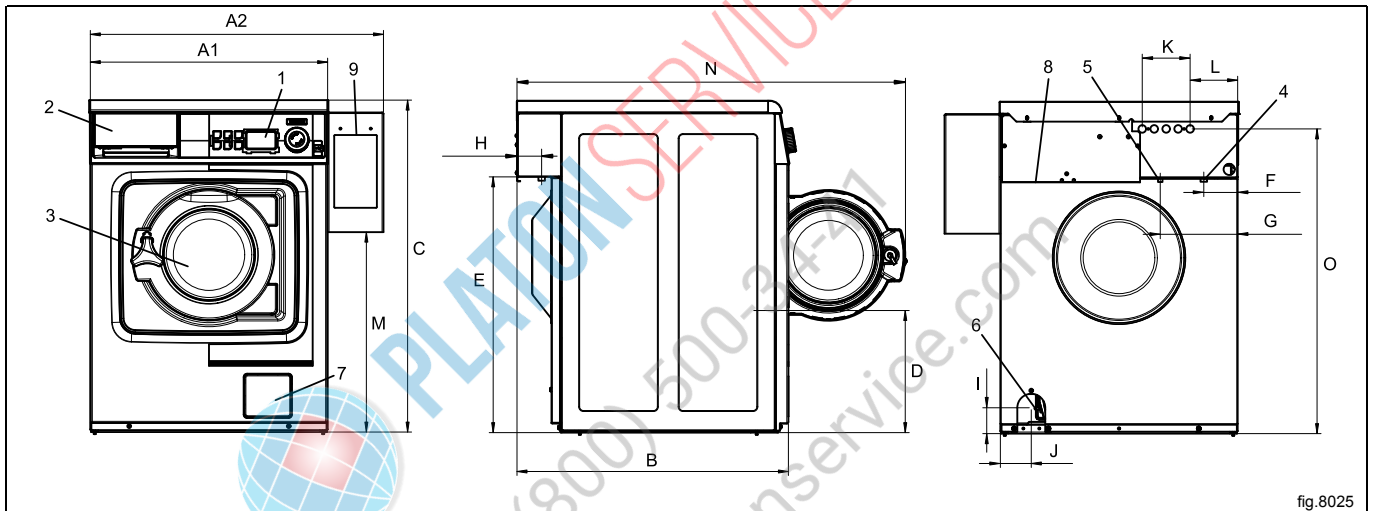

fig.8025

1	Operating panel
2	Detergent container
3	Door opening, $\varnothing$ 255 mm
4	Cold water
5	Hot water
6	Drain valve
7	Drain pump
8	Electrical connection
9	Payment system

	A1	A2	B	C	D	E	F	G
mm	595	735	681	832*	306	641	84	194

	H	I	J	K	L	M	N	O
mm	48	65	78	120	119	501	974	764

\* Adjustable height: 25 mm.

## 2.2 Technical data

Weight, net	kg	100
Drum volume	litres	53
Drum diameter	mm	452
Drum speed during wash	rpm	35/54
Drum speed during extraction	rpm	1450
Drum speed during extraction, Marine model	rpm	1300
G-factor, max.		530
G-factor, max. Marine model		425
Heating: Electricity	kW	4.4
Heating: Hot water		x
Frequency of the dynamic force	Hz	24.2
Floor load at max extraction	kN	1.2±0.3
A-weighted emission sound pressure level at working stations (Wash)	dB(A)	<70
A-weighted emission sound pressure level at working stations (Extraction)	dB(A)	72

## 2.3 Connections

Water valves	DN BSP	20 3/4"
Capacity at 300 kPa	l/min	17
Drain valve	∅ outer mm	50
Draining capacity (pump)	l/min	160

## 3 Machine presentation

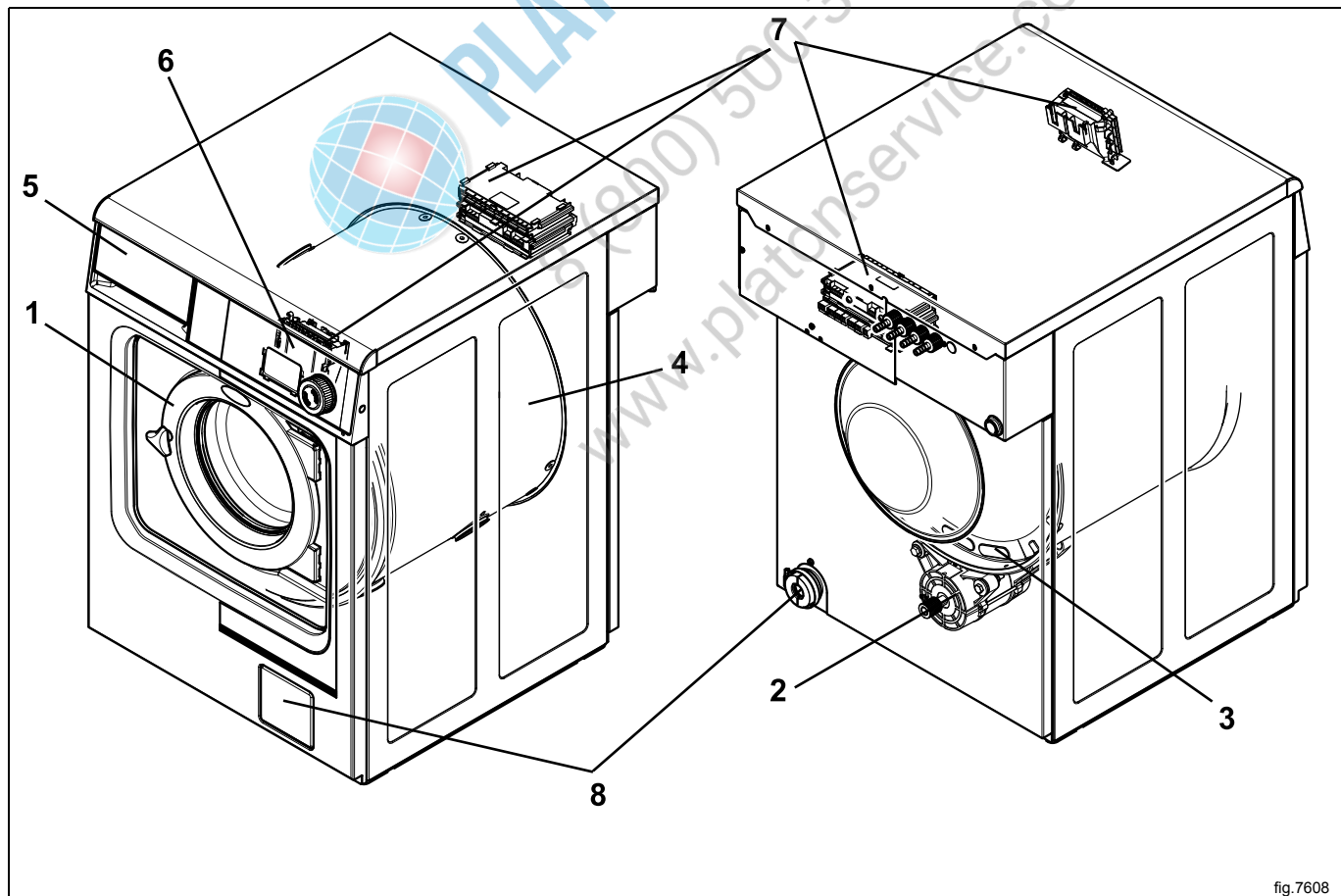

fig.7608

1	Door
2	Motor
3	Heating unit
4	Drum
5	Detergent container
6	Control panel with Control system
7	I/O modules
8	Drain / Drain pump

### After a repair has been made

Whenever a repair has been made, a function check must be performed before the machine can be used again.

## 4 Function check



May only be carried out by qualified personnel.



A function check must be made when the installation is finished and before the machine can be ready to be used.

Open the manual water valves.

Add detergent in the compartment for main wash and start a program.

- Check that the drum rotates normally and that there are no unusual noises.
- Check that there are no leaks in water supply/drain connections.
- Check that water passes through the detergent container.
- Check that the door cannot be opened during a program.

### Ready to use

If all tests are OK the machine is now ready to be used.

If some of the tests failed, or deficiencies or errors are detected, please contact your local service organisation or dealer.

## 5 Door and door lock

### 5.1 Door lock

The door lock consists of:

- An actuator that locks the door lock and also has one built-in micro switch. The actuator is bi-stable, i.e., it has two stable positions: locked door and unlocked door. The actuator must receive a pulse to lock and unlock the door lock.
- A micro switch that is closed when the door is closed.
- An emergency opening button that can be used to open the door lock in an emergency .

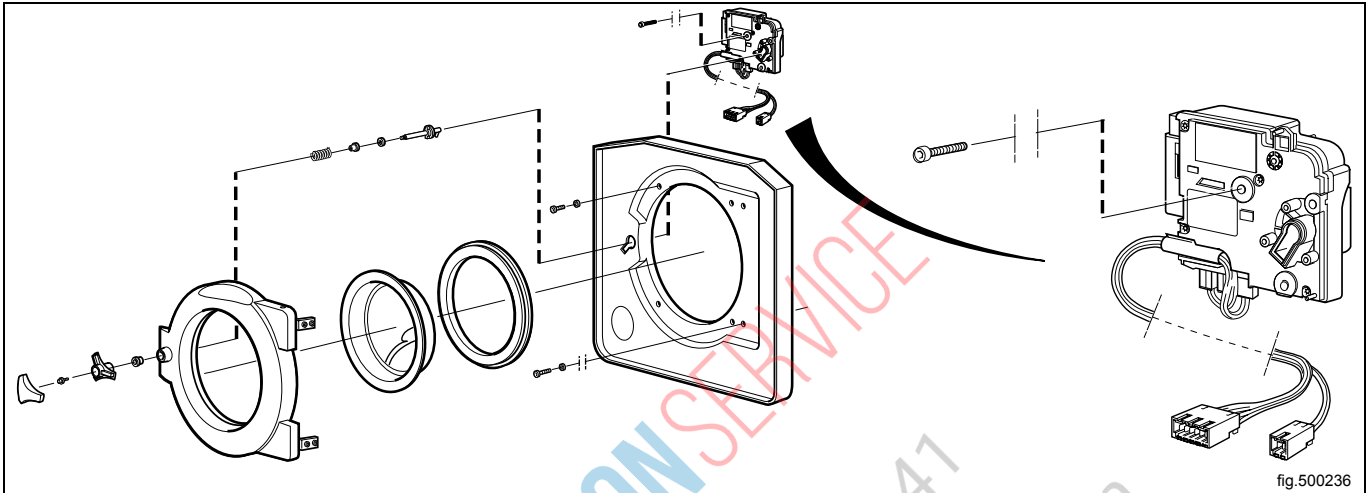

#### Replacement of door lock

Disconnect the power to the machine.  
Demount the front panel.

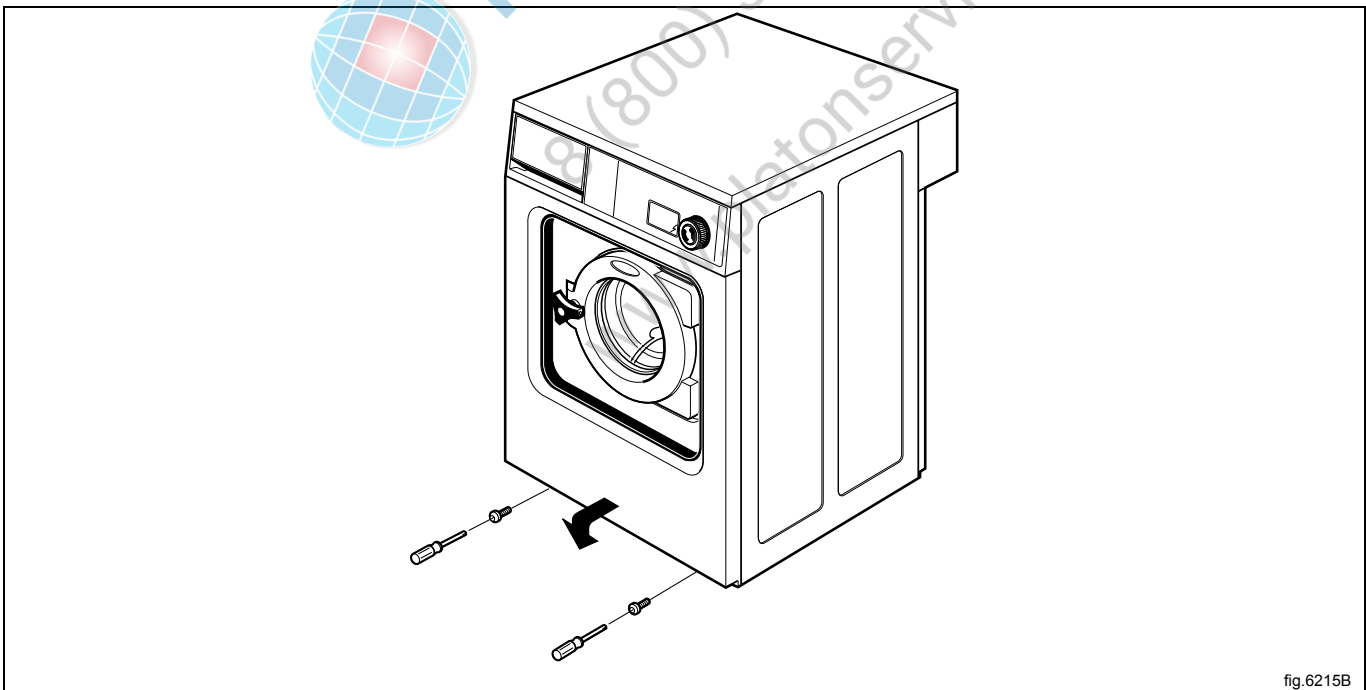



Demount the door.  
Demount the trim panel.  
Disconnect the door lock cables and demount the door lock.

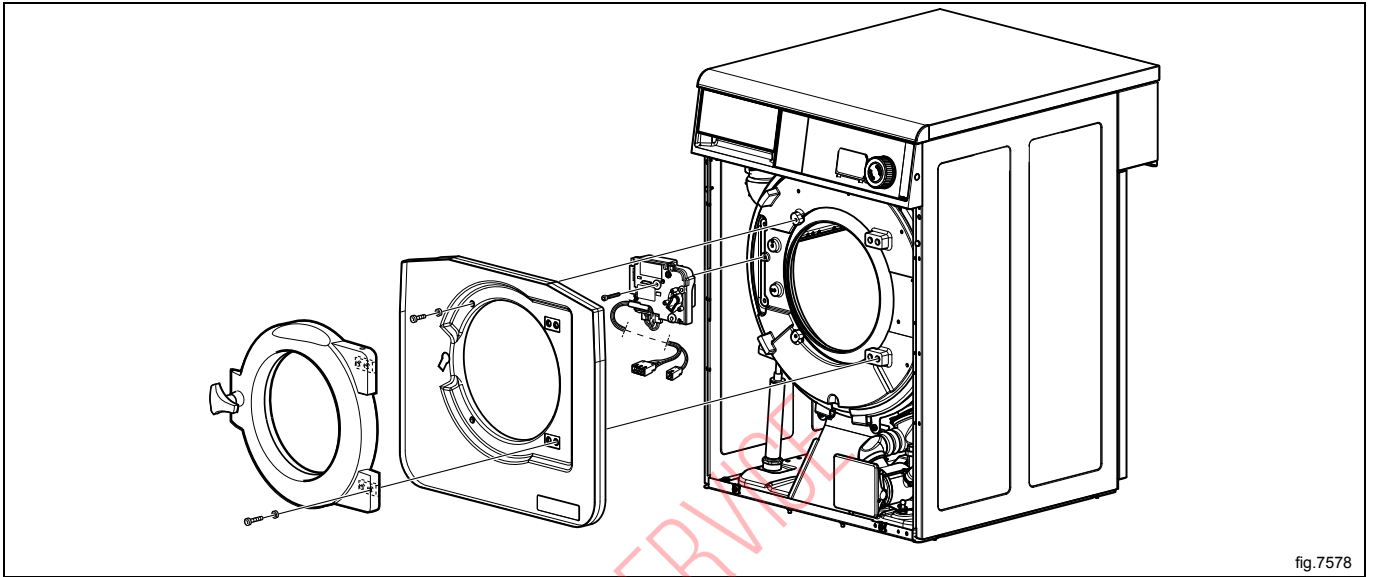

fig.7578

Mount the new door lock and connect the cables.  
Mount the trim panel.  
Mount the door and the front panel.

#### Emergency opening of door lock

The door can be opened by pressing the emergency opening button.

To access the emergency opening button, remove the front panel. The emergency opening button can be reached between the left side panel and the trim panel. If not accessible, remove also the trim panel.

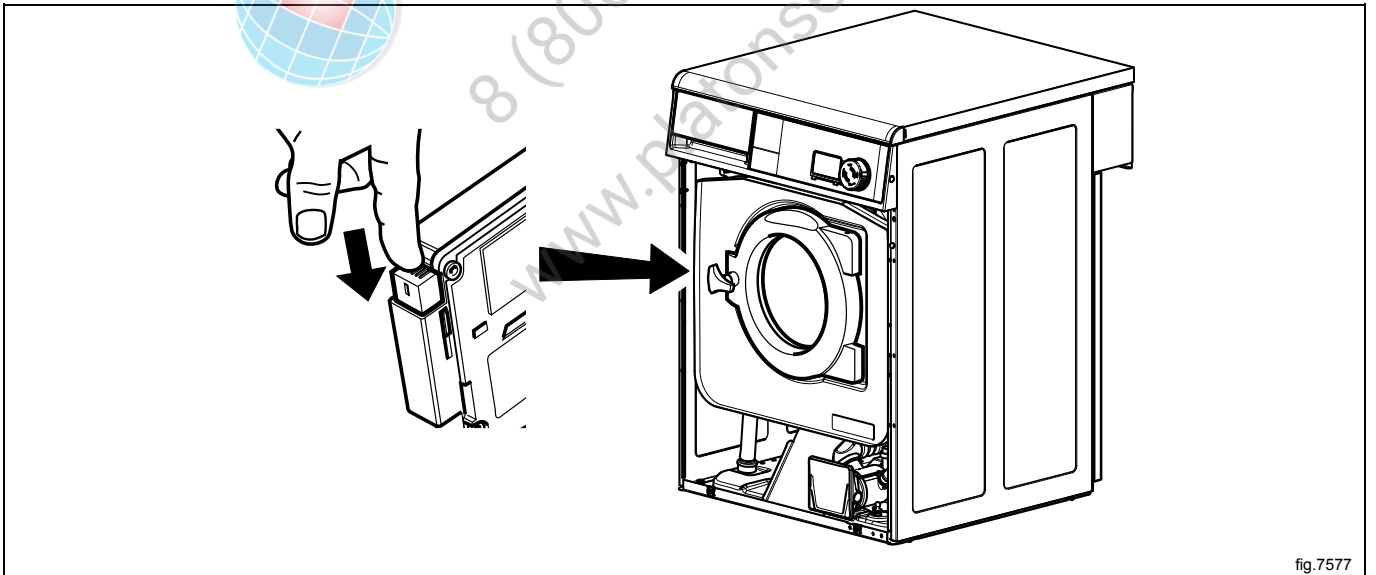

fig.7577

## 5.2 Door handle

### 5.2.1 Replacement of door handle

Disconnect the power to the machine.

Remove the plastic cover on the door handle. Be careful not to damage the door handle.

Remove the center screw (A) and demount the door handle.

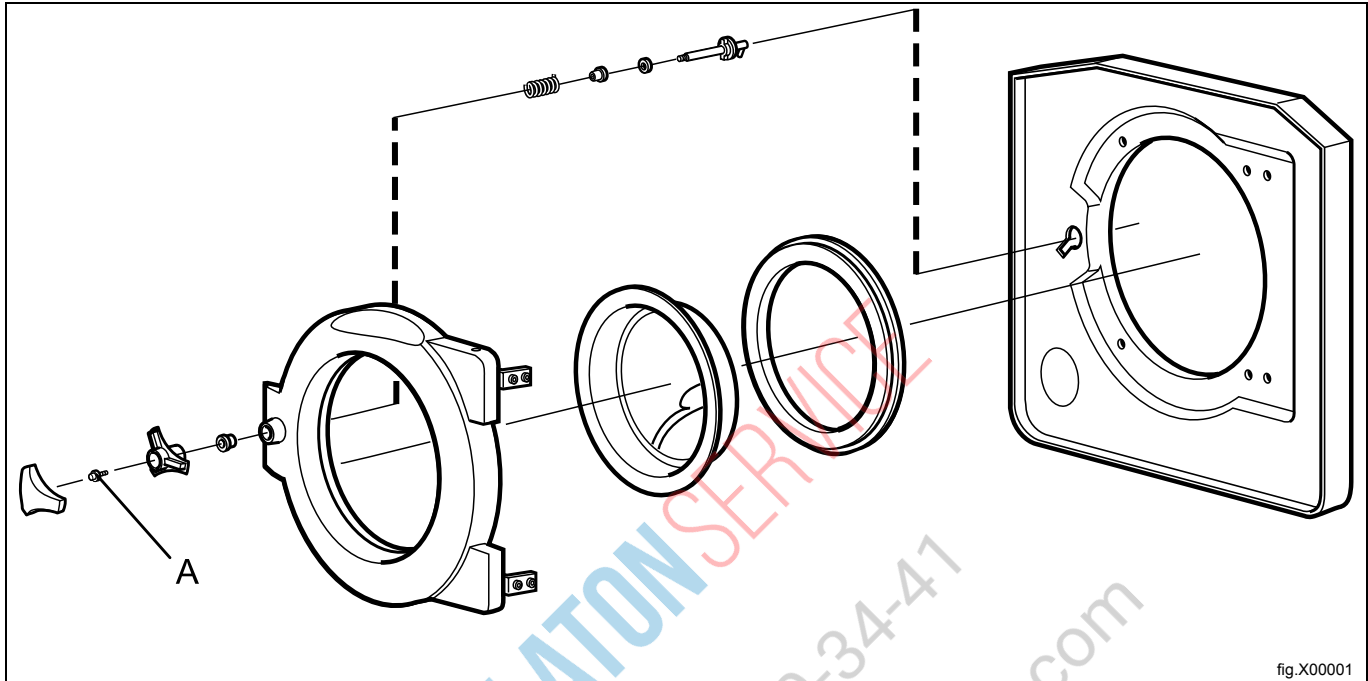

fig.X00001

Mount the new door handle and tighten the center screw to 15 Nm / 11 lbf-ft.

## 5.3 Problems and solutions

### 5.3.1 Door knob creating noise or feeling loose

#### Problem

The center screw inside the door knob is loose or is not tightened enough. This is causing the door handle to feel loose and/or creating noise.

#### Solution

Hold the L-pin on the axis still against one side on the door and turn the knob in each direction. If there is any play while turning the center screw must be tightened.

- Disconnect the power to the machine.
- Remove the plastic cover on the door handle. Be careful not to damage the door handle.
- Tighten the center screw to 15 Nm / 11 lbf-ft.
- Remount the plastic cover.
- When the center screw has been tightened there shall not be any play while turning the door handle.

The enclosed animation shows the process. To start the animation: [Click here](#)

## 6 Motor and motor control

### 6.1 Motor control unit

The motor control unit communicates with the control system via a serial (input/output) interface. With the aid of the motor control unit the control system can control not only the speed of the motor at any given point, but also the acceleration or deceleration rate at which the motor is to achieve the speed required. The motor control unit constantly feeds information on current status (both normal status and on any abnormalities arising) back to the control system. The motor control unit can also supply data on the different torque and effect of the motor at constant speed when accelerating and deceleration. These data are used both for calculating the weight of the load and for detecting any unbalance.



The voltage on the motor control circuit has a potential difference of approx. 300 V in relation to incoming neutral and earth. Because of this, be careful when measuring. Use unearthed oscilloscopes. If the motor control unit has a green LED, this will remain lit for as long as there are hazardous voltages present in components.

### 6.2 Replacement of motor

Disconnect the power to the machine.

Demount the rear panel.

Remove the belt.

Disconnect the motor cable and unscrew the earth screw.

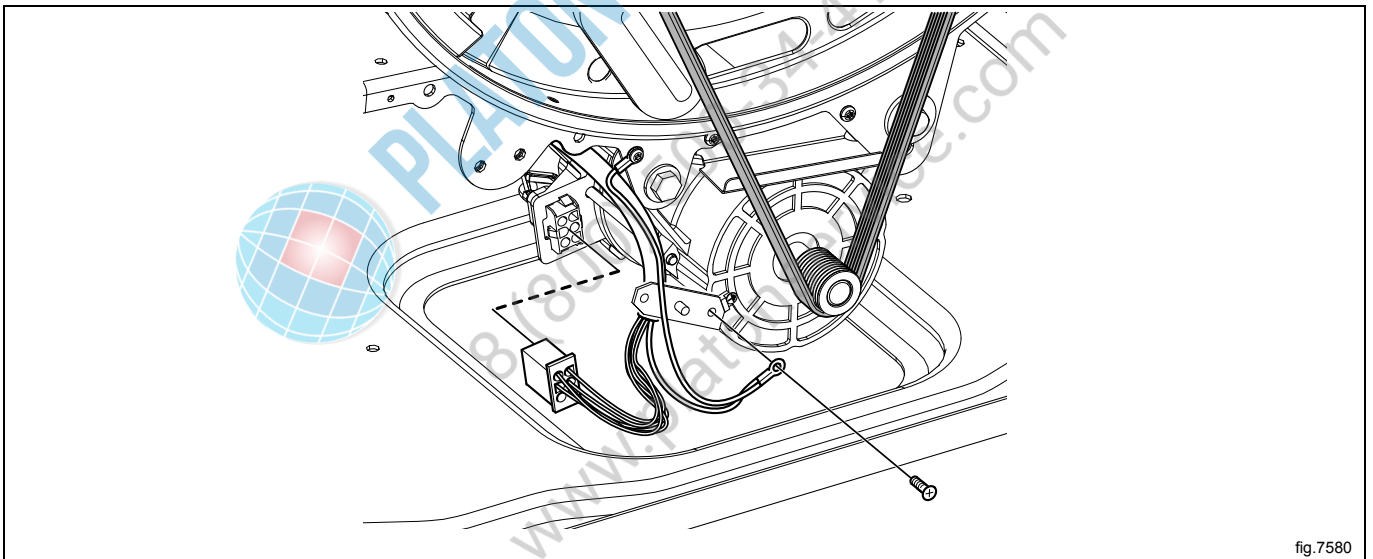
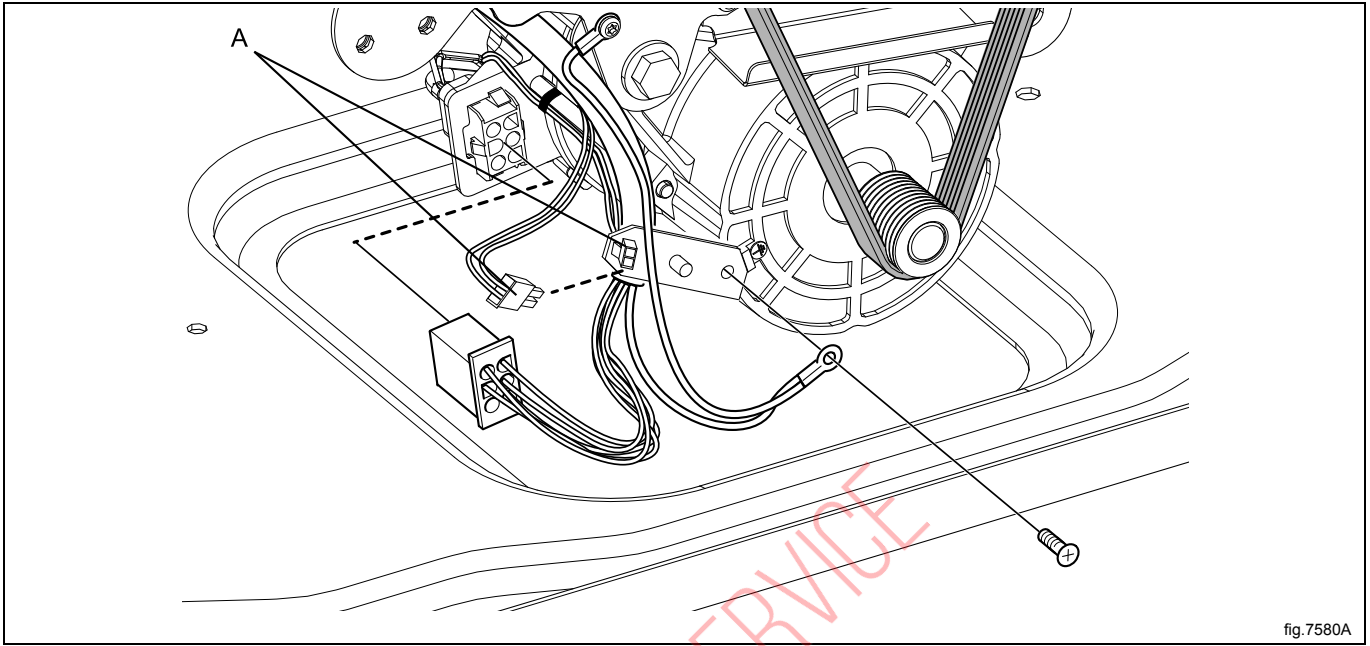
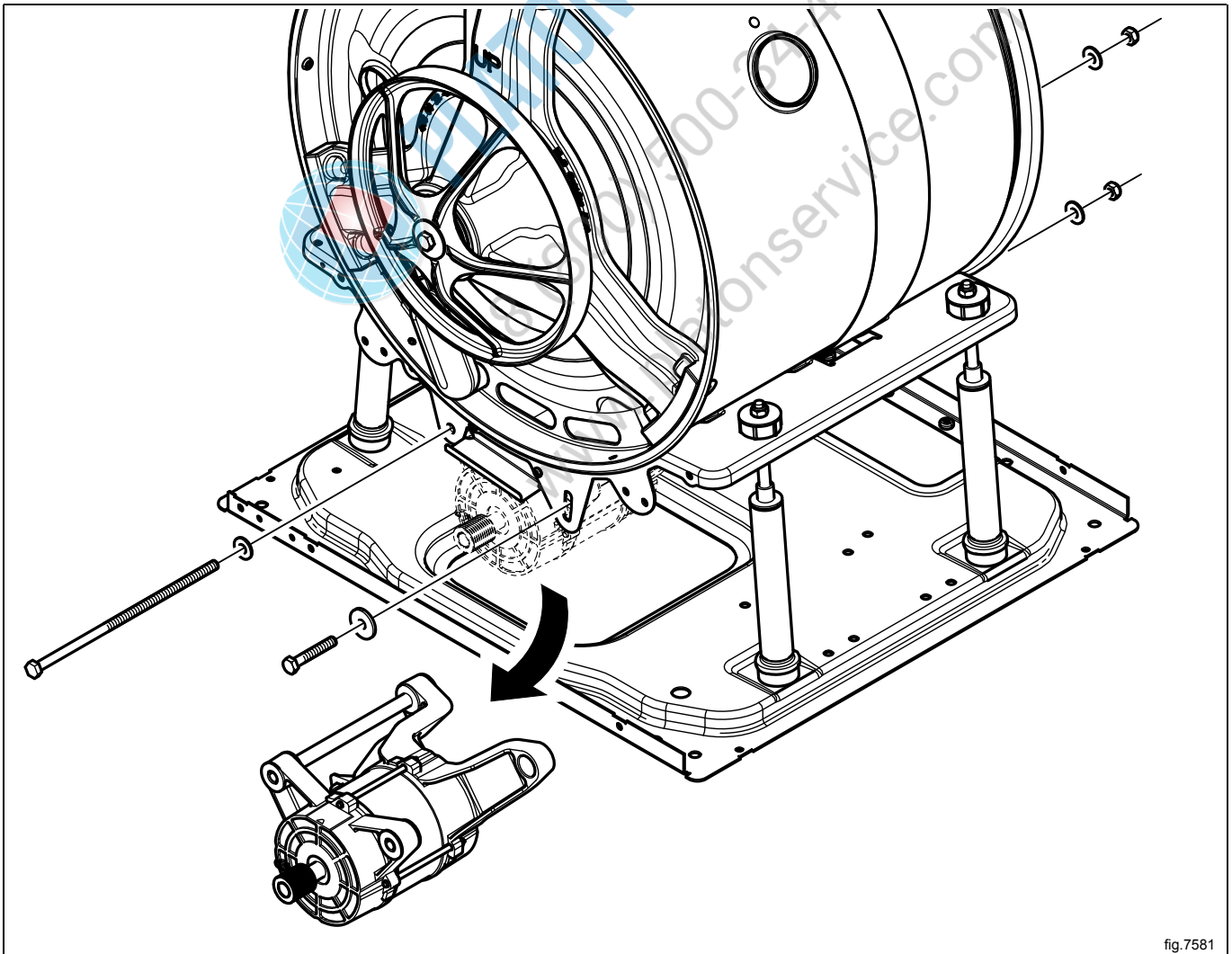

fig.7580

Disconnect the cables for thermal protection (A) if the motor is fitted with a thermal switch.



Demount the motor. Start with the bolt to the right and then the bolt to the left.



Mount the new motor. Start with the bolt to left and then the bolt to the right.

Fasten the belt. Make sure the belt is in position.

Check the belt tension with a frequency meter or similar. The frequency shall be  $70 \text{ Hz} \pm 5$ . Adjust if necessary with the right screw in the slotted hole.

Connect the motor cable (and the cable for thermal protection if the motor is fitted with a thermal switch) and refit the earth screw.

Disconnect the cable for thermal protection (A) if the motor is fitted with a thermal switch.

Mount the rear panel.

### 6.3 Replacement of the belt

Disconnect the power to the machine.

Demount the back panel.

Remove the belt (A) and put the new belt in position. Check the belt tension with a frequency meter or similar. The frequency shall be  $70 \text{ Hz} \pm 5$ . Adjust if necessary with the right screw in the slotted hole.

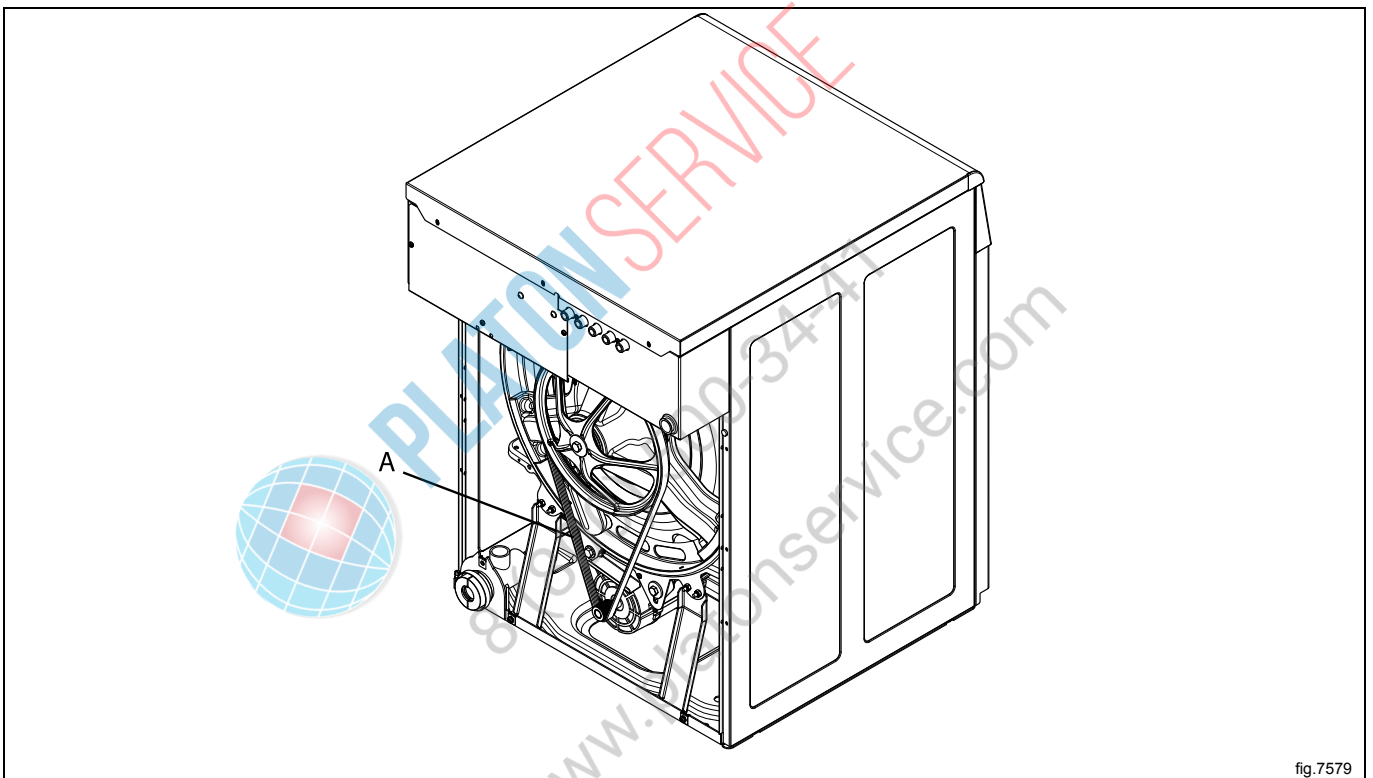

Remount the back panel.

Connect the power to the machine.

## 7 Heating

### 7.1 Replacement of heating element

Disconnect the power to the machine.

Demount the rear panel.

Remove the belt (A).

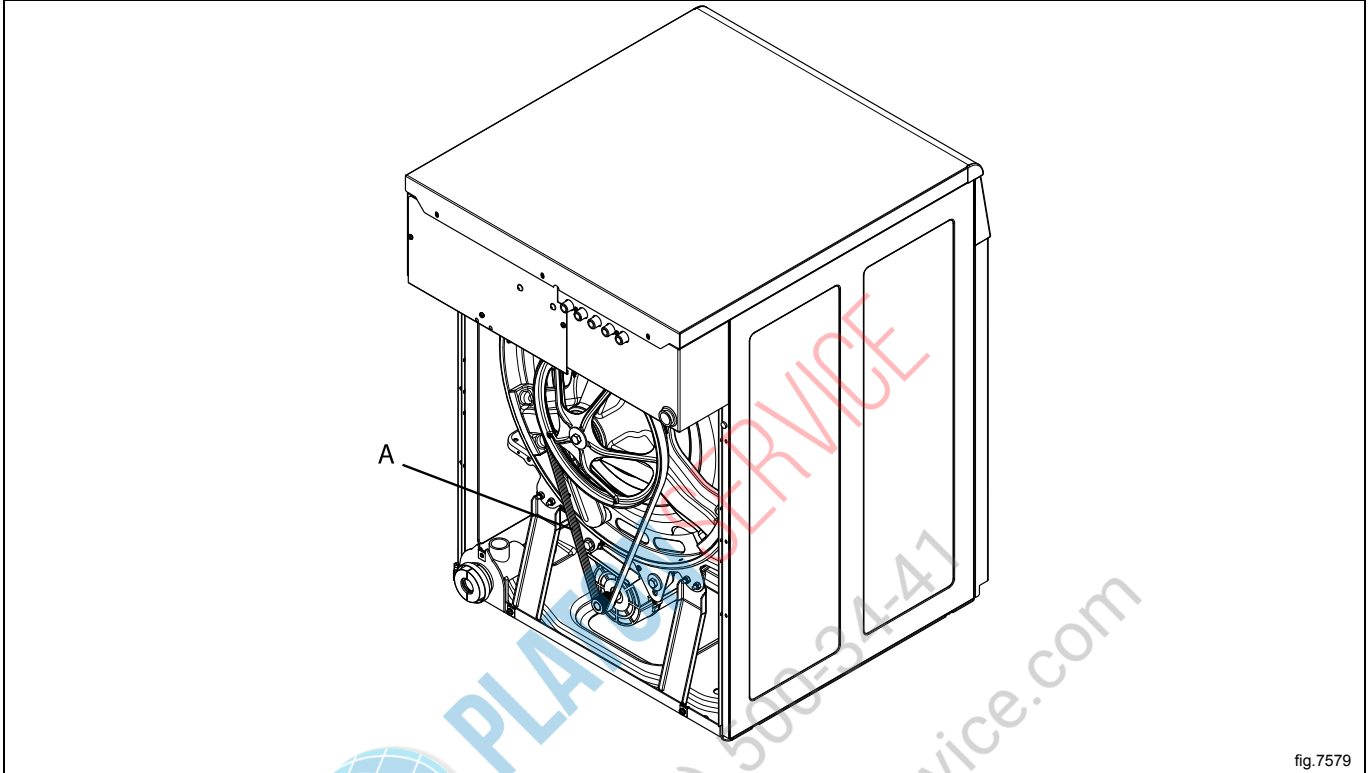

Disconnect the connectors to the heating element.

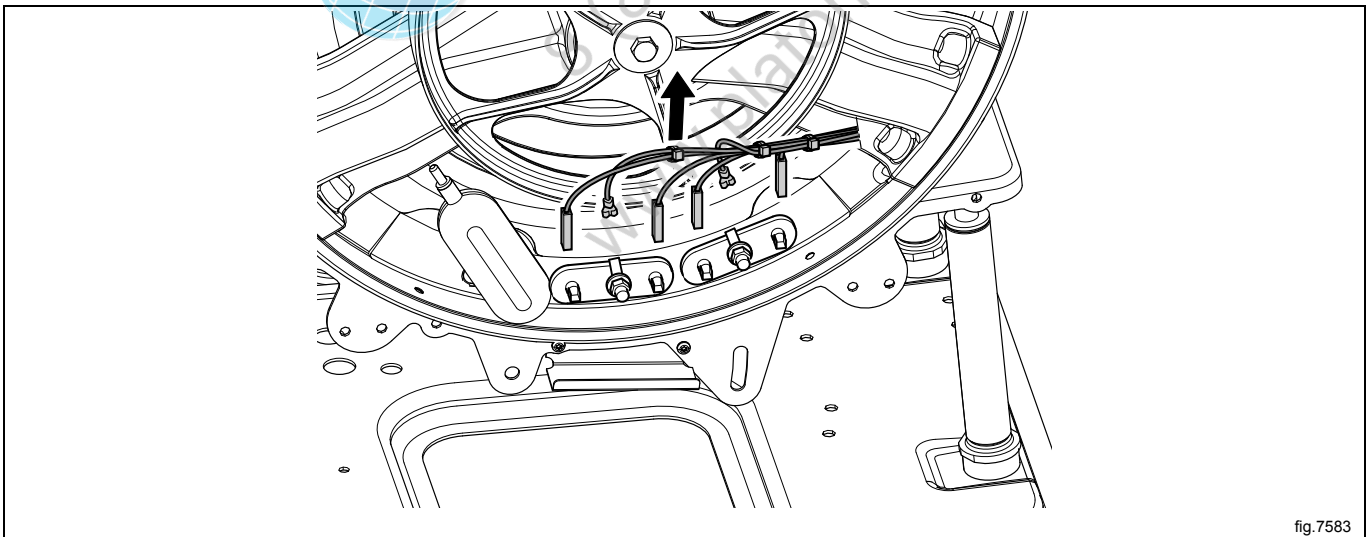

Loosen the bolt to the heating element and gently push on the middle of the heating element to release the flange. Remove the heating element and insert the new heating element.

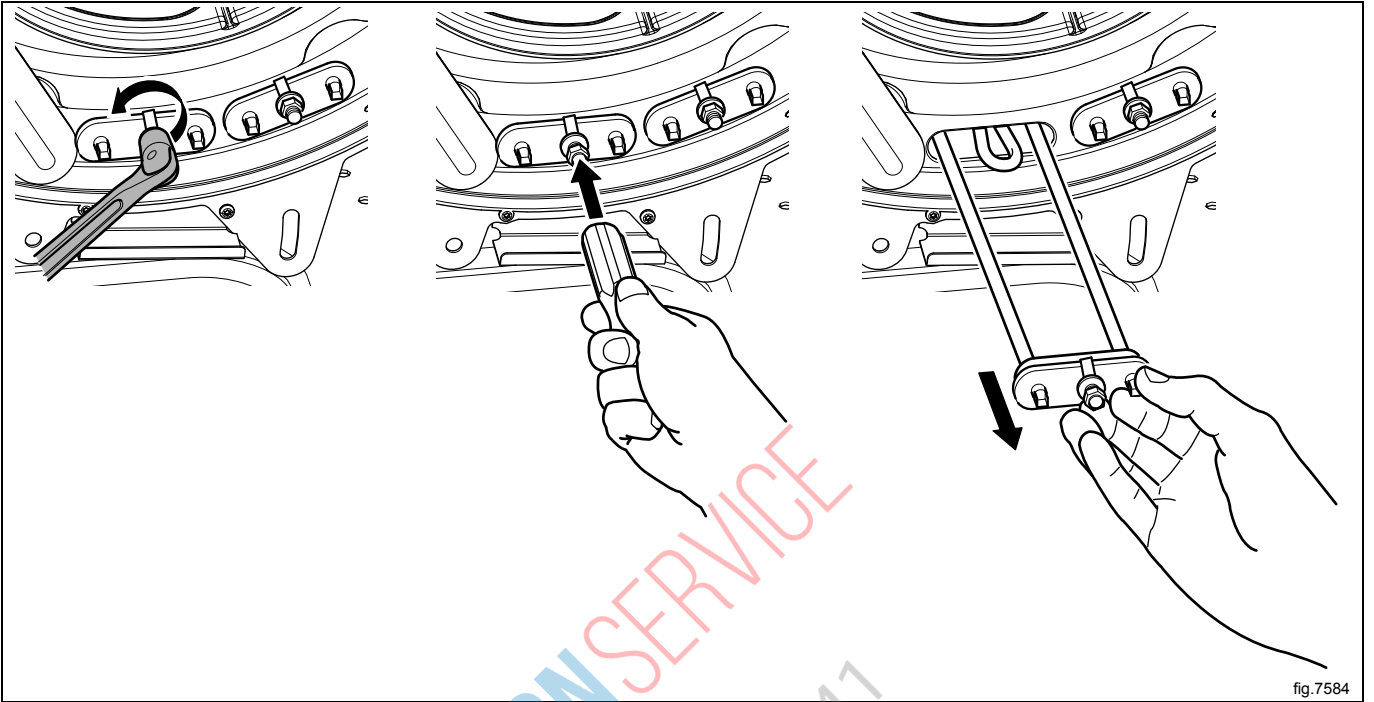

fig.7584

Push on the middle of the heating element to get the flange in position. Fasten the bolt. Use tightening torque 6 Nm. Reconnect the connectors to the heating element, use the electric schematic supplied with the machine.

## 8 Drum

### 8.1 Replacement of drum

Disconnect the power to the machine.

Demount the top panel, the front— and back panels.

Demount the door.

Demount the trim panel.

Demount the door lock and the rotation guard. Cut the cable ties and disconnect the level sensor, motor cable and earth cable at the back of the machine.

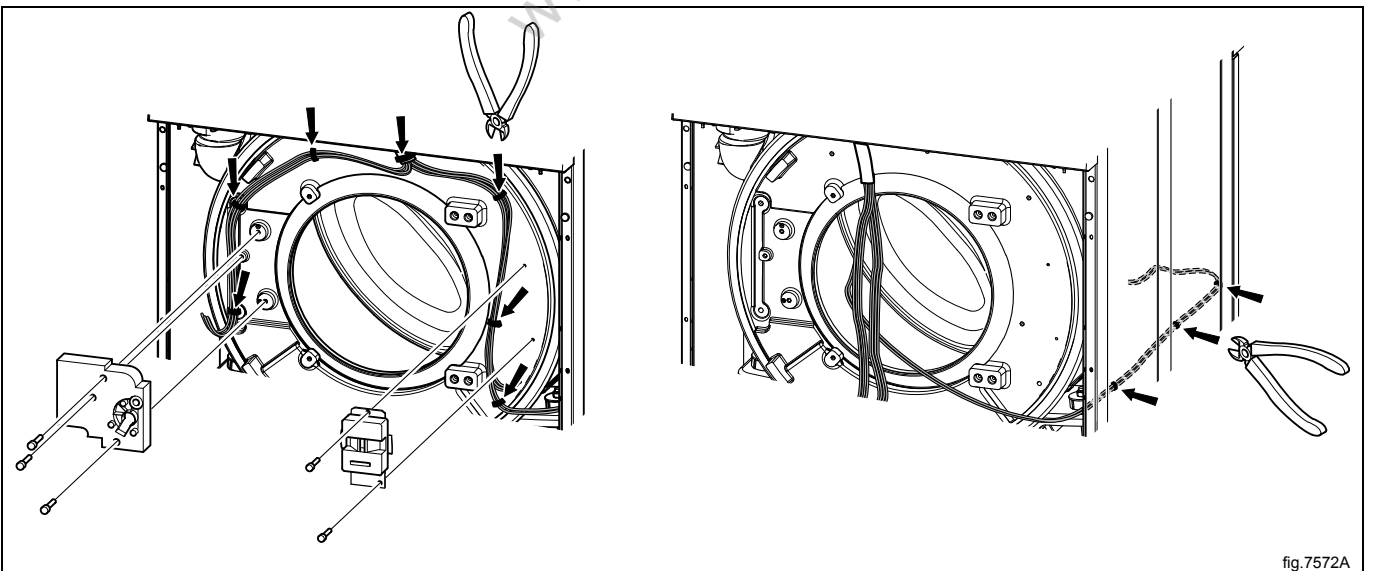

fig.7572A



Demount the drain and hoses to the drum. Drain and type of hoses are depending on machine model, for more information refer to the spare parts list.

Demount the air hose and the hose from the detergent compartment on top of the drum.

Remove the belt.

Disconnect the connectors to the heating elements. Loosen the bolt to the heating element and gently push on the middle of the heating element to release the flange. Remove all heating elements.

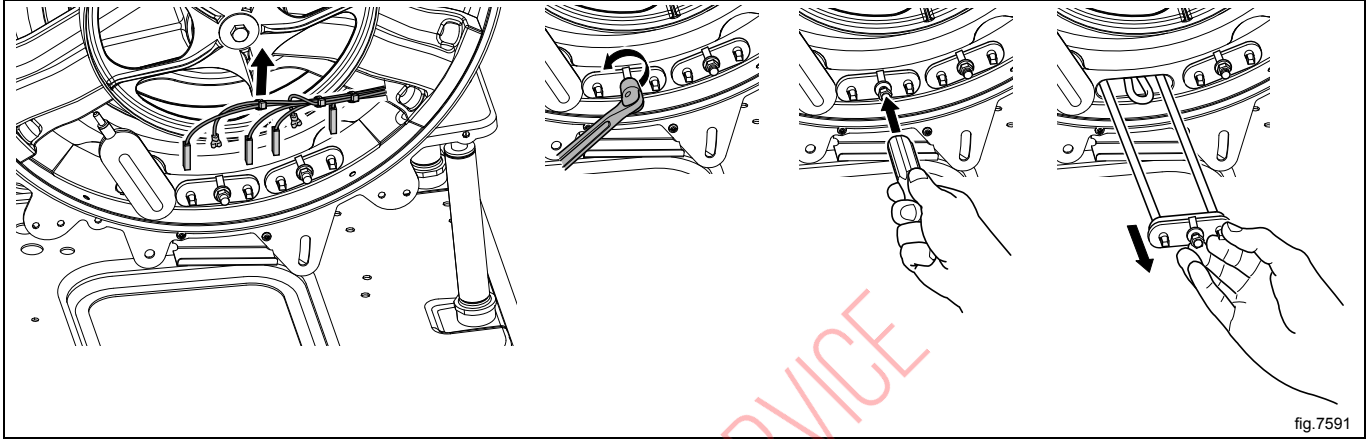

Disconnect the inlet hose and the vent hose from the drum.

Unscrew the screws to the side panels and lift of the cabinet to release the drum package.

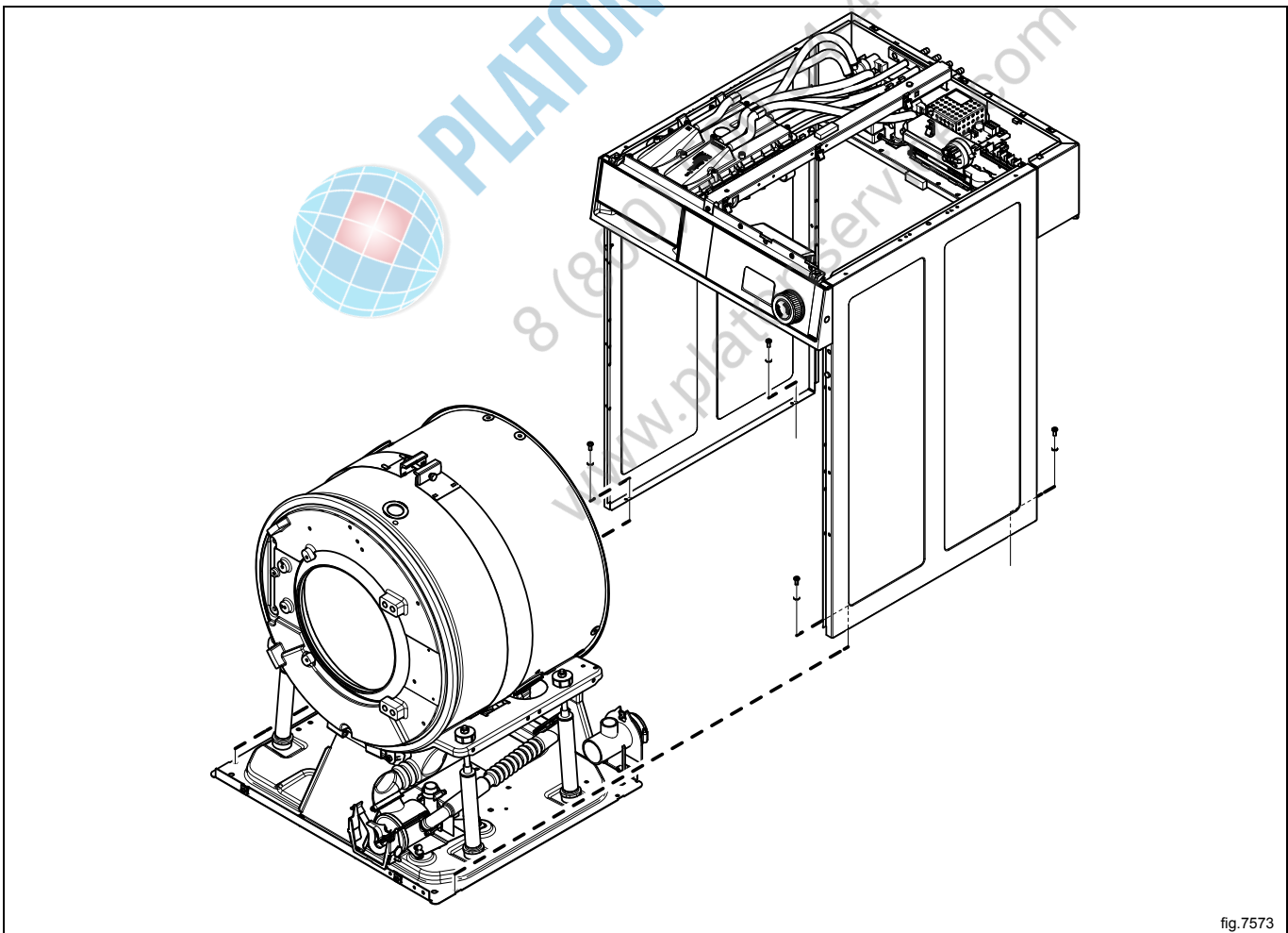



Demount the counter weight by loosening the tension strap.

**Note!**

Note the position of the counter weight. When remounting it must be remounted in exactly the same position.

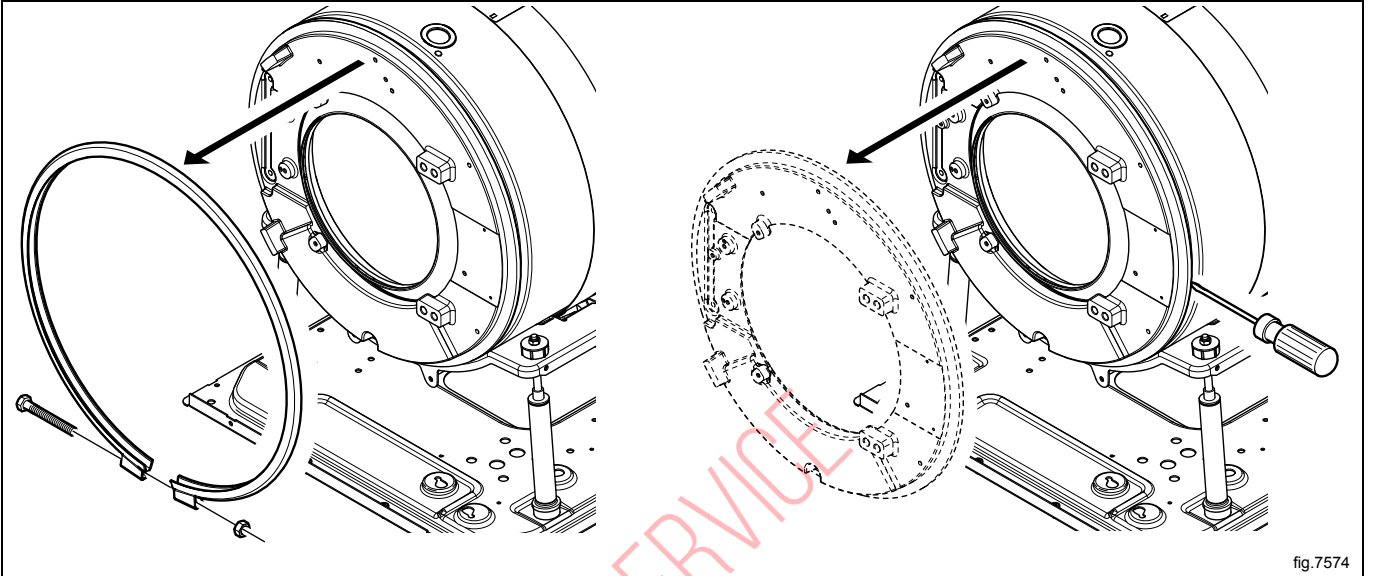

fig.7574

Loosen the tensioner holding the drum and remove the drum.

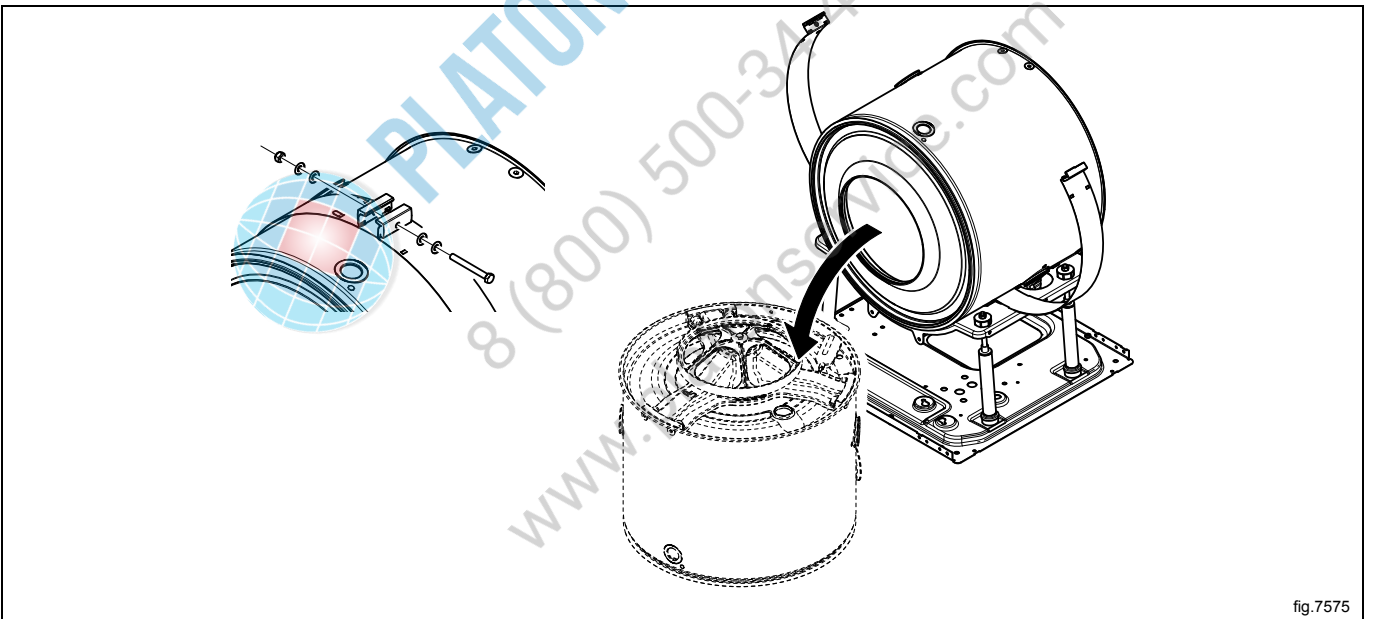

fig.7575

Mount the new drum. Make sure to position the drum over the screw in the rear flange.

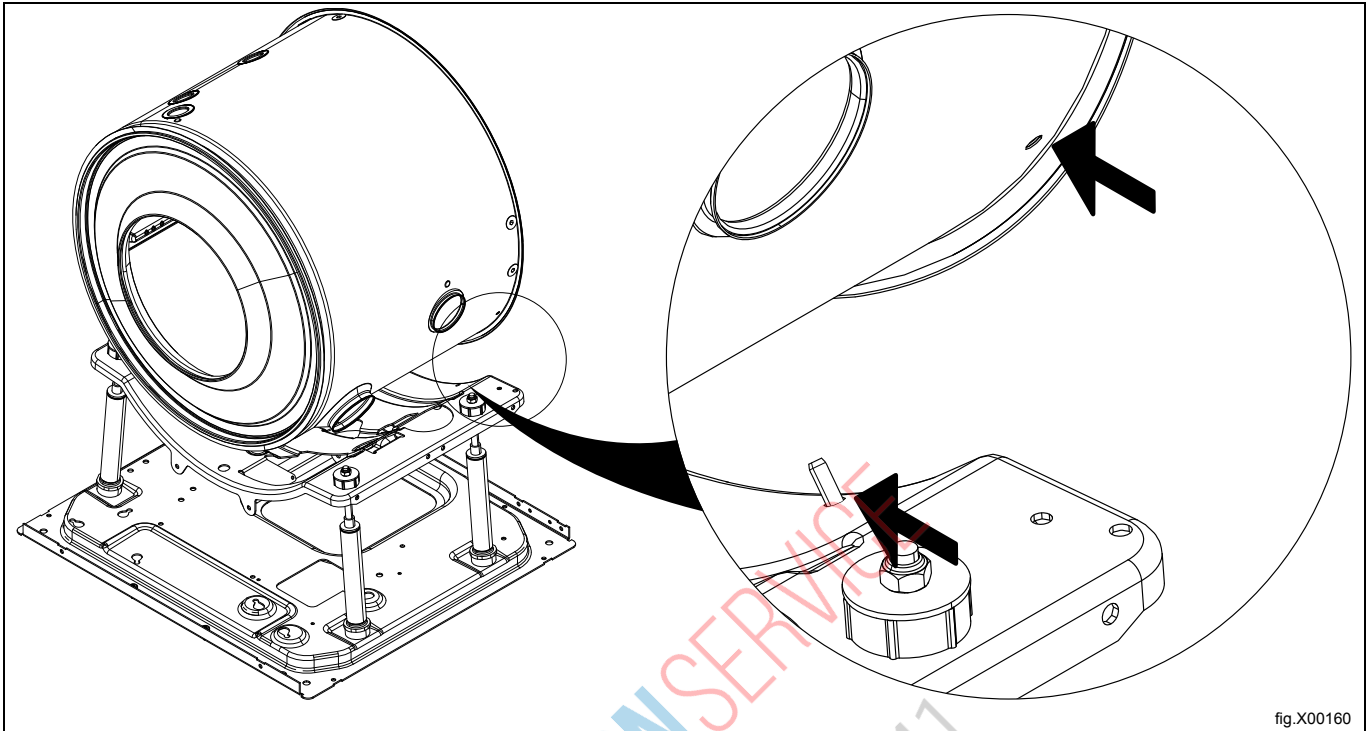

fig.X00160

Fasten the tensioner and mount the counter weight with the tension strap.

**Note!**

The counter weight must be remounted in the exact position as before.

Use a spirit level between the two door hinge guide pins to make sure to get them in vertical position.

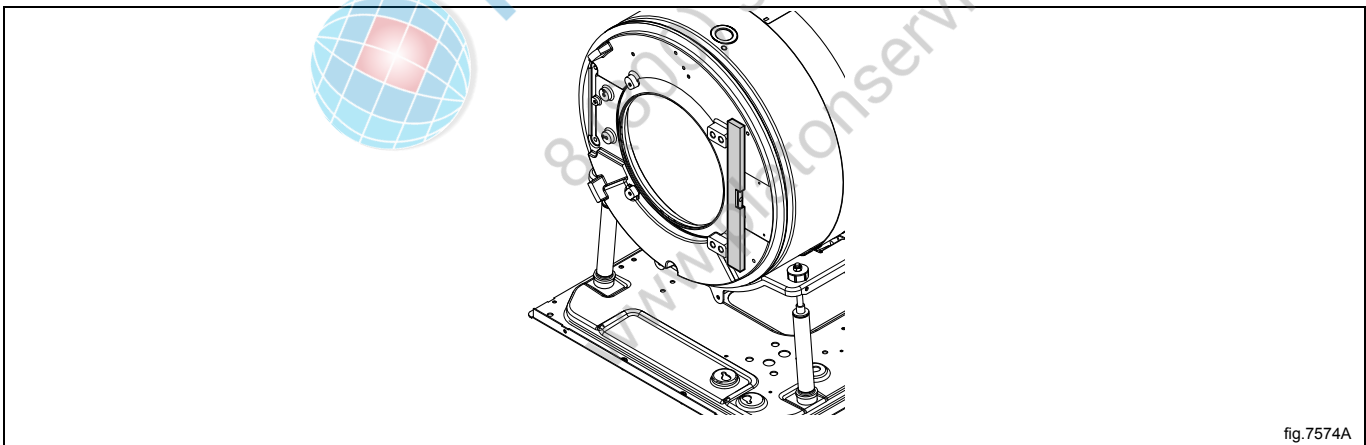

fig.7574A

Mount the heating elements, hoses and drain in the same position as before.

Fasten the belt. Make sure the belt is in position. Check the belt tension with a frequency meter or similar. The frequency shall be  $70 \text{ Hz} \pm 5$ . Adjust if necessary.

Remount the cabinet.

Connect the inlet hose and the vent hose to the drum.

Remount the level sensor, motor cable and earth cable at the back of the machine.

Remount the door lock and the rotation guard.

Fasten the cables with cable ties in the same position as before.

Remount the trim panel and the door.

Remount the top panel, the front— and back panels.

Connect the power to the machine.

## 9 Drain

### 9.1 Drain valve

The water pressure in the cold water intake is used for closing the drain valve. There is a hose (1) connected between the water intake and the control valve (2). When the control valve is activated it opens and lets water into the supply line (3) which is connected to the drain valve. The water presses up a rubber membrane (4) and a plunger (5) with a pressure plate (6) which closes the valve's rubber membrane (7).

When the control valve shuts off water pressure to the drain valve the springs (8) pull back the plunger. The return water passes the control valve and runs out into the drain via the return hose (9).

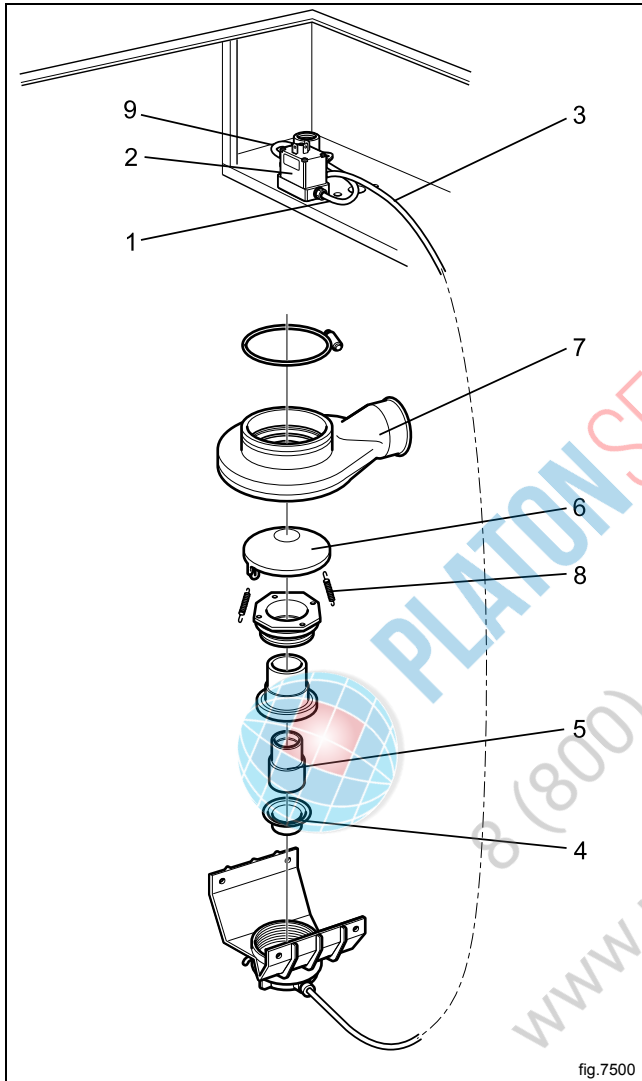

### Replacement of drain valve

Disconnect the power to the machine.

Demount the front panel.

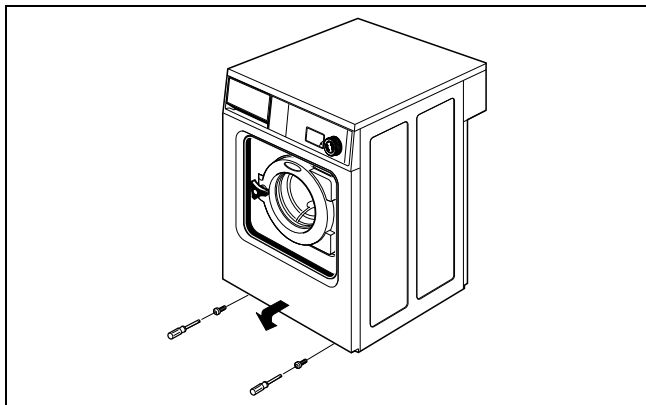

Demount the door.

Demount the trim panel.

Remove the hose from the valve's nipple for water supply (A). (Press the orange ring and pull out the hose at the same time).

Remove the nut but leave the bolt (B) in place, securing the drain valve to the right-hand side of the saddle. Remove the bolts (C) securing the drain valve on the left-hand side of the saddle. Pull down the left side of the drain valve a little and then lift the drain valve off from the right-hand bolt. Demount the drain valve from the hose (D).

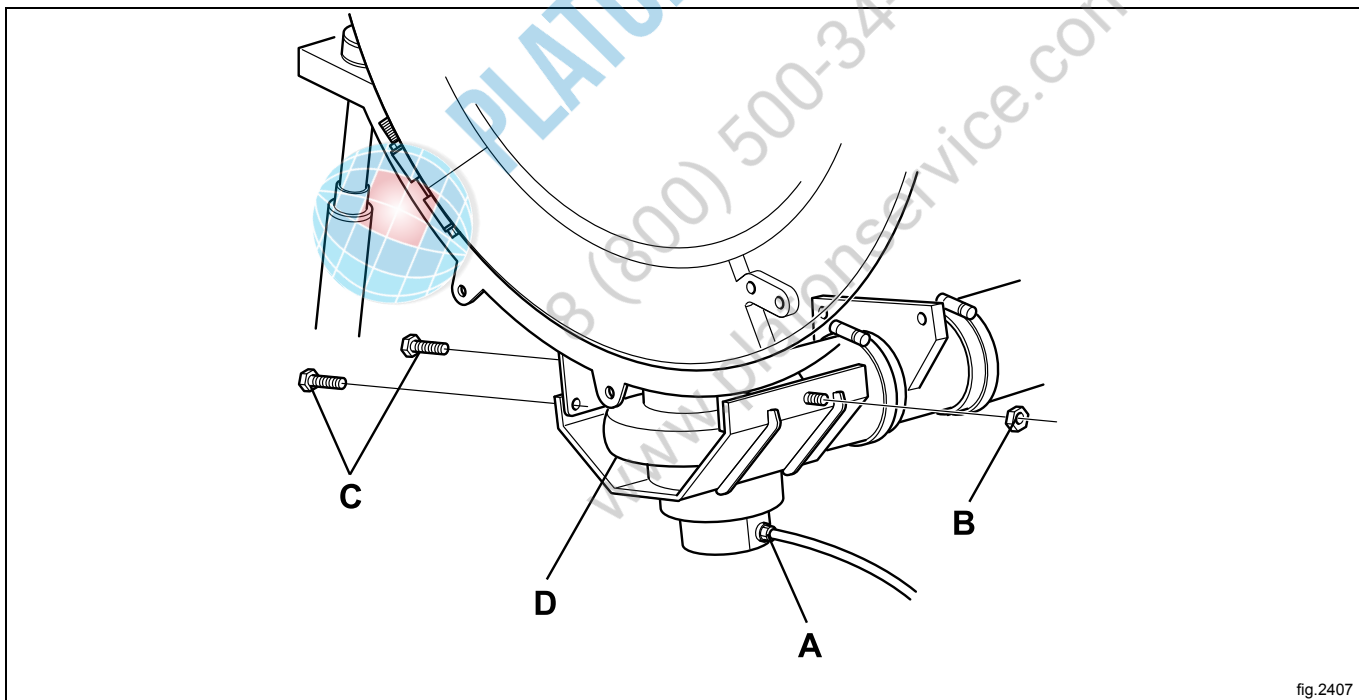

fig.2407

Mount the new drain valve.

Mount the drain valve onto the right-hand bolt (B) on the saddle. Mount the bolts (C) on the left-hand side of the saddle. Tighten the bolt (B).

Mount the hose for water supply (A).

Mount the hose from the drum (D) on the drain valve. The rubber edge on the hose shall be pulled down over the valve cover. Check that the hose edge snaps into place over the lower edge of the cover.

Mount the trim panel, the door and the front panel.

## 9.2 Drain pump

The drain pump is located under the drum. Access the drain pump through a door on the front of the machine. The motor which drives the pump is activated from the timer.

### Replacement of drain pump

Open the door to the drain pump and pull out the hose. Remove the plug (A) to empty the drain into for example a baking plate or similar.

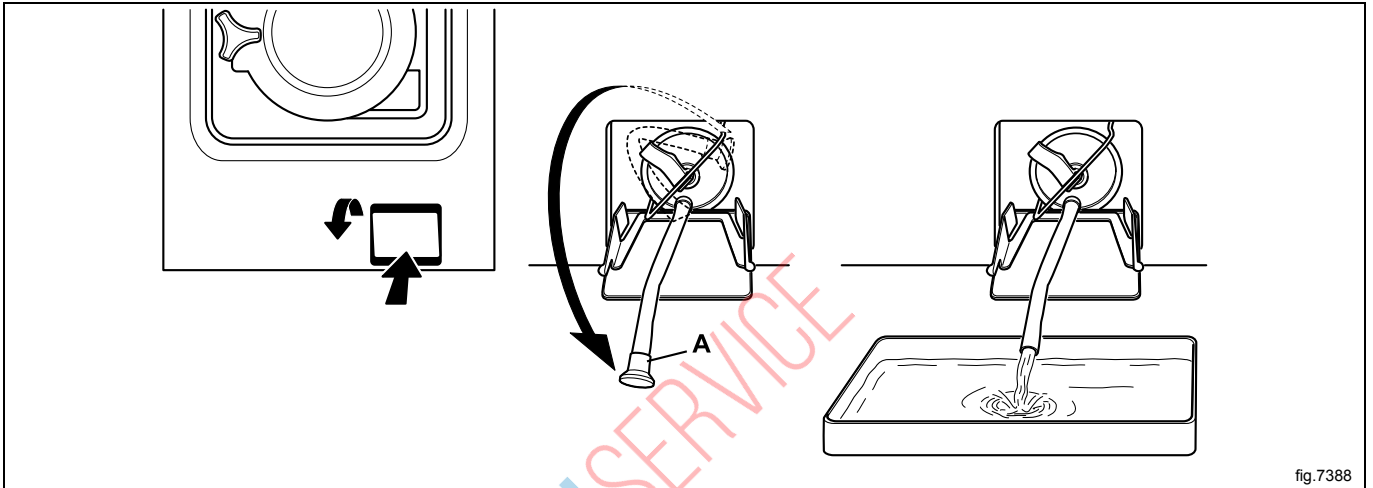

fig.7388

Demount the hoses to the drain pump.

Demount the plastic plugs holding the pump in position and remove the drain pump.

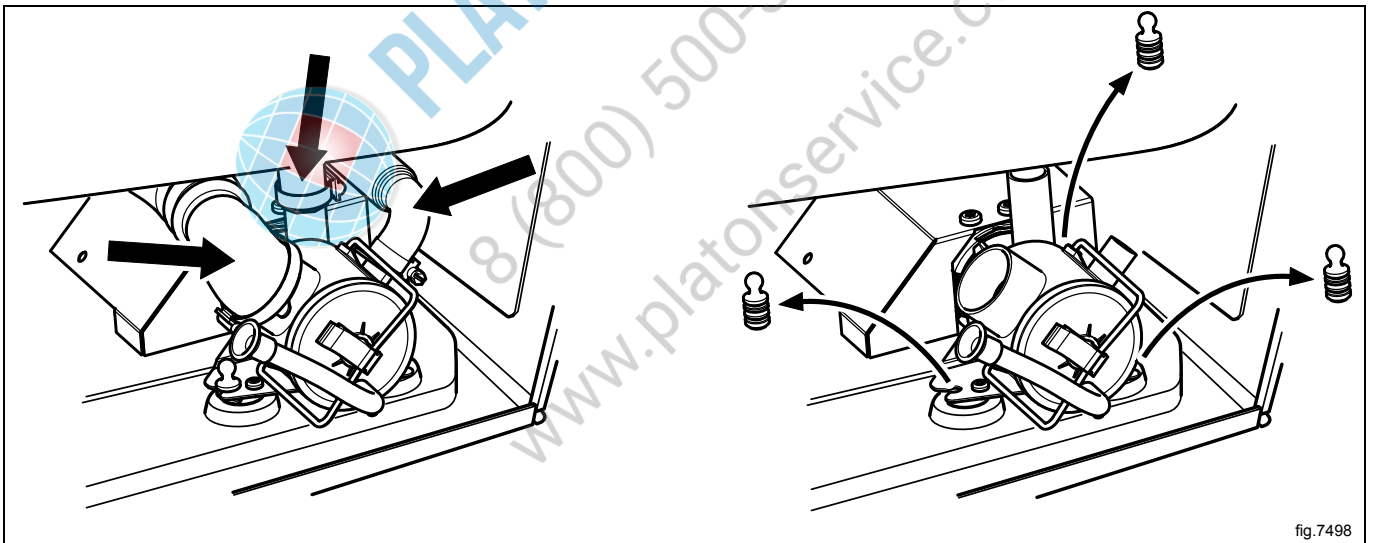

fig.7498

Mount the new drain pump and fasten the plastic plugs.

Remount the hoses and make sure the connections are tight.

Refit the plug (A) and close the door.

## 10 Detergent container

Water connections into the detergent container are fitted with dispensers which mix the detergent thoroughly with water and flush the compartments clean. From the bottom of the detergent container the water is flushed down into the drum.

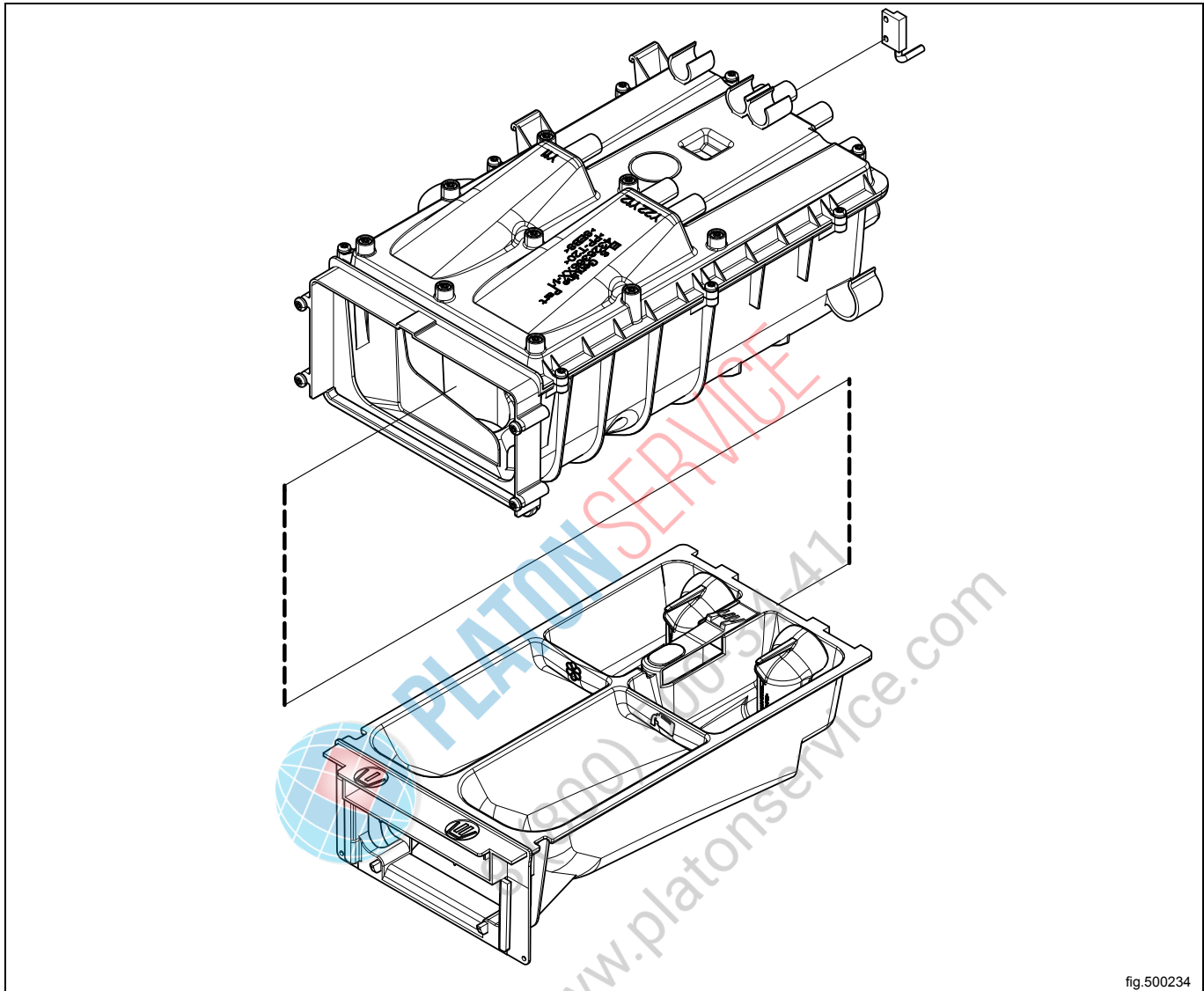

fig.500234

### 10.1 Replacement of detergent container

Remove the detergent container from the machine and replace with the new one.

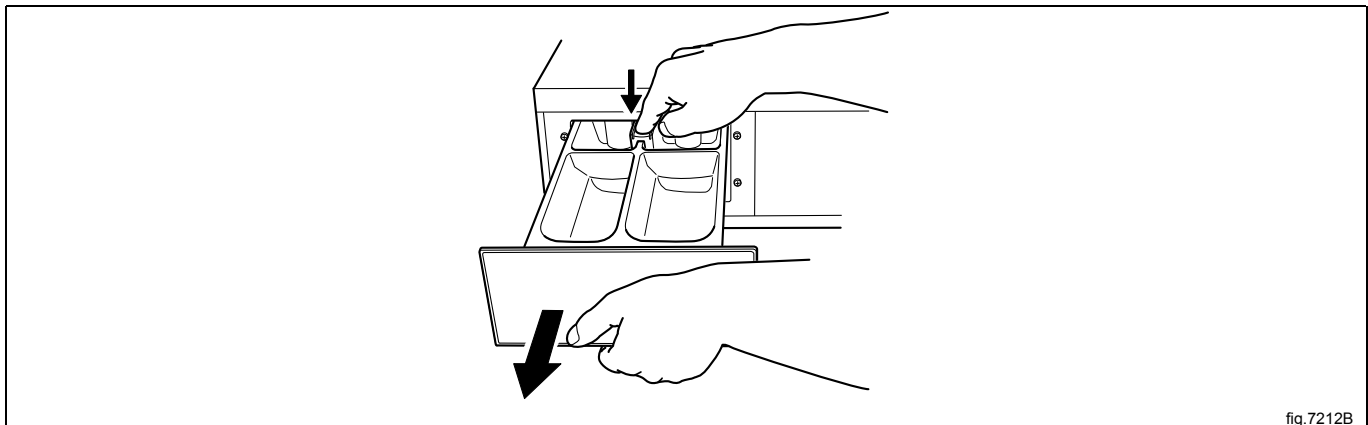

fig.7212B

## 10.2 Replacement of siphon

Remove the detergent container from the machine and remove the siphon to be replaced. Mount the new siphon.

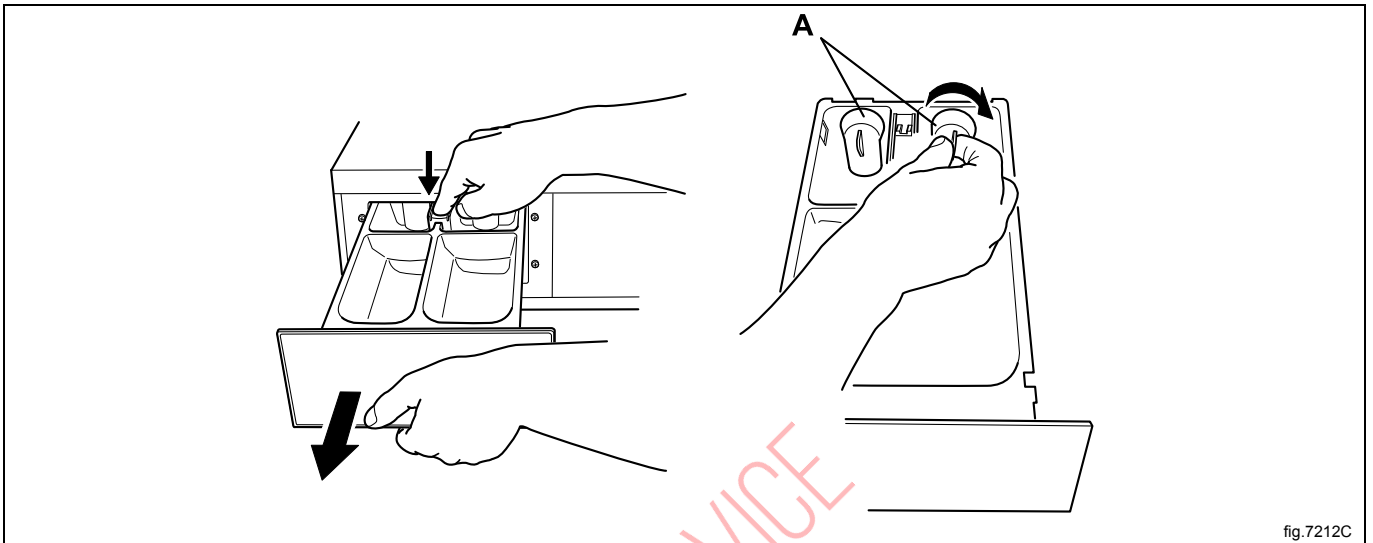

fig.7212C

## 10.3 Replacement of reed switch

Disconnect the power to the machine.

Demount the top panel.

Disconnect the cable from the program unit.

Remove the reed switch by pulling it out a bit and down from its position.

Mount the new reed switch and make sure it is in position. Connect the cable in the same position as before.

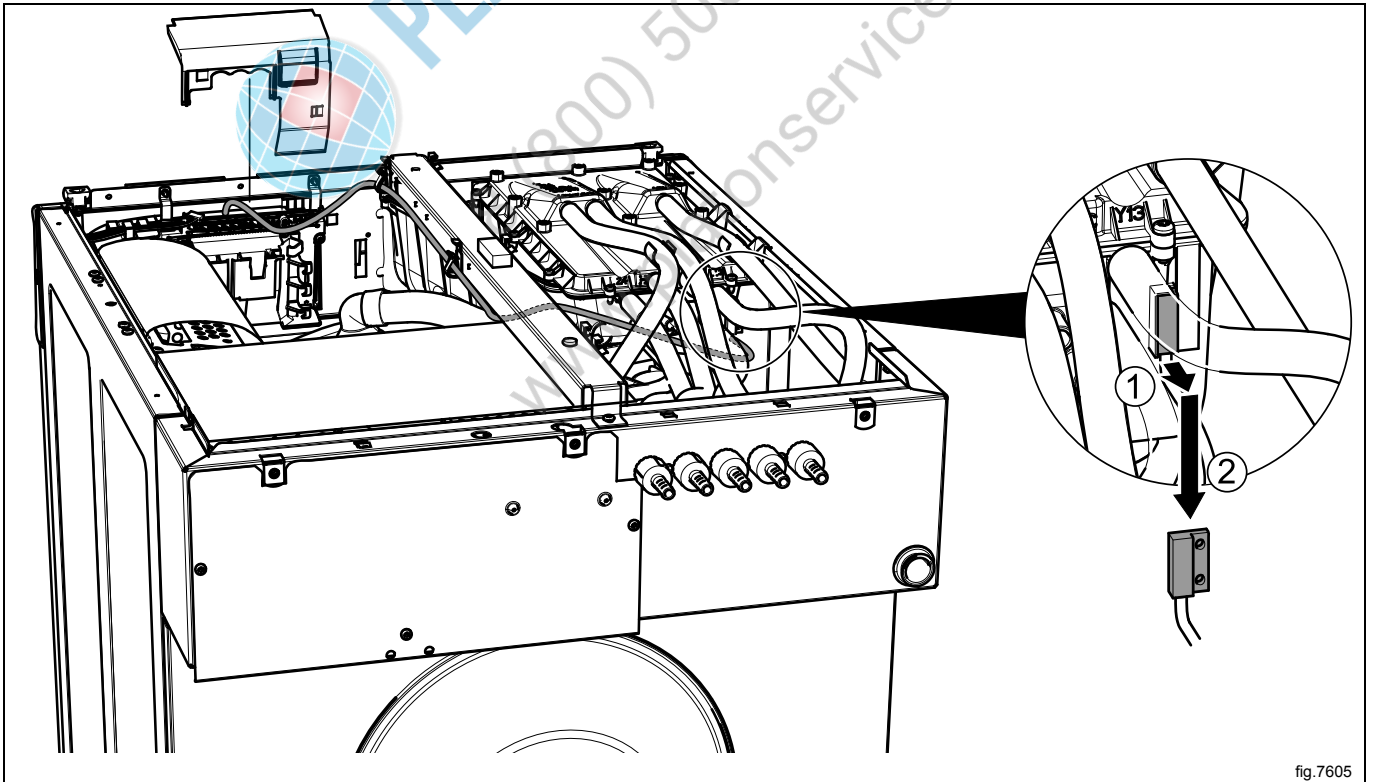

fig.7605

## 11 Control panel

### 11.1 Control system

#### 11.1.1 Description

The control system CPU is electronic and comprises a circuit board containing microprocessor, program memory, serial interface to the motor control, I/O-boards etc.

The control system CPU receives its power from a separate power supply unit.

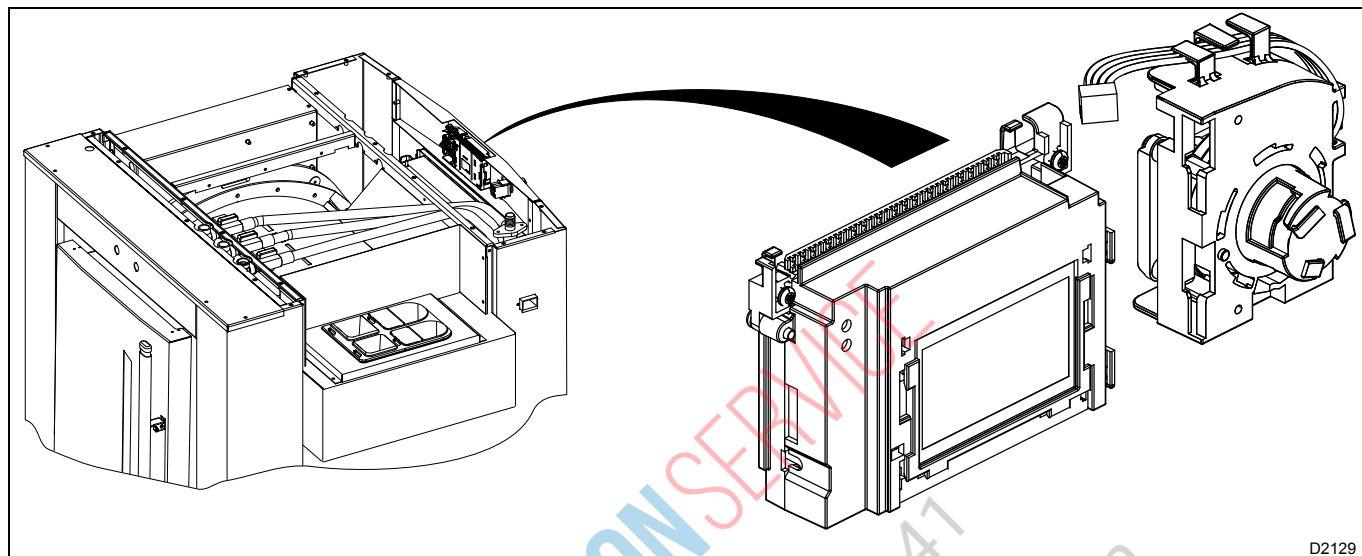

The control system receives information about inputs like temperature sensor, level sensor, door status and activates outputs like water valves, drain and heat control.



PLATON SERVICE  
8 (800) 500-34-41  
www.platonservice.com



### 11.1.2 Connections

The control system CPU and I/O module type 10 has the following connections:

Board connector	Function
M-COM	Communication, motor control
D-BUS	Databus
D-BUS	Databus
TACHO	Tachometer
COIN	Coin meter (coin 1, coin 2, blocking) price programming
INP 1	Input 1, stop button
INP 2	Free program (key switch) / Input 2
RS 232	Serial communication
ENC	Control knob (pulses)
USB TYPE B	Connection for software / service download
PIN CONNECTOR	Panel sign connector
LEVEL	Level controls
DO	Door out, door lock solenoid
OUTP	Output
DOOR IN	Door lock micro switches
P-BUS	Power bus
TEMP	Temp sensor

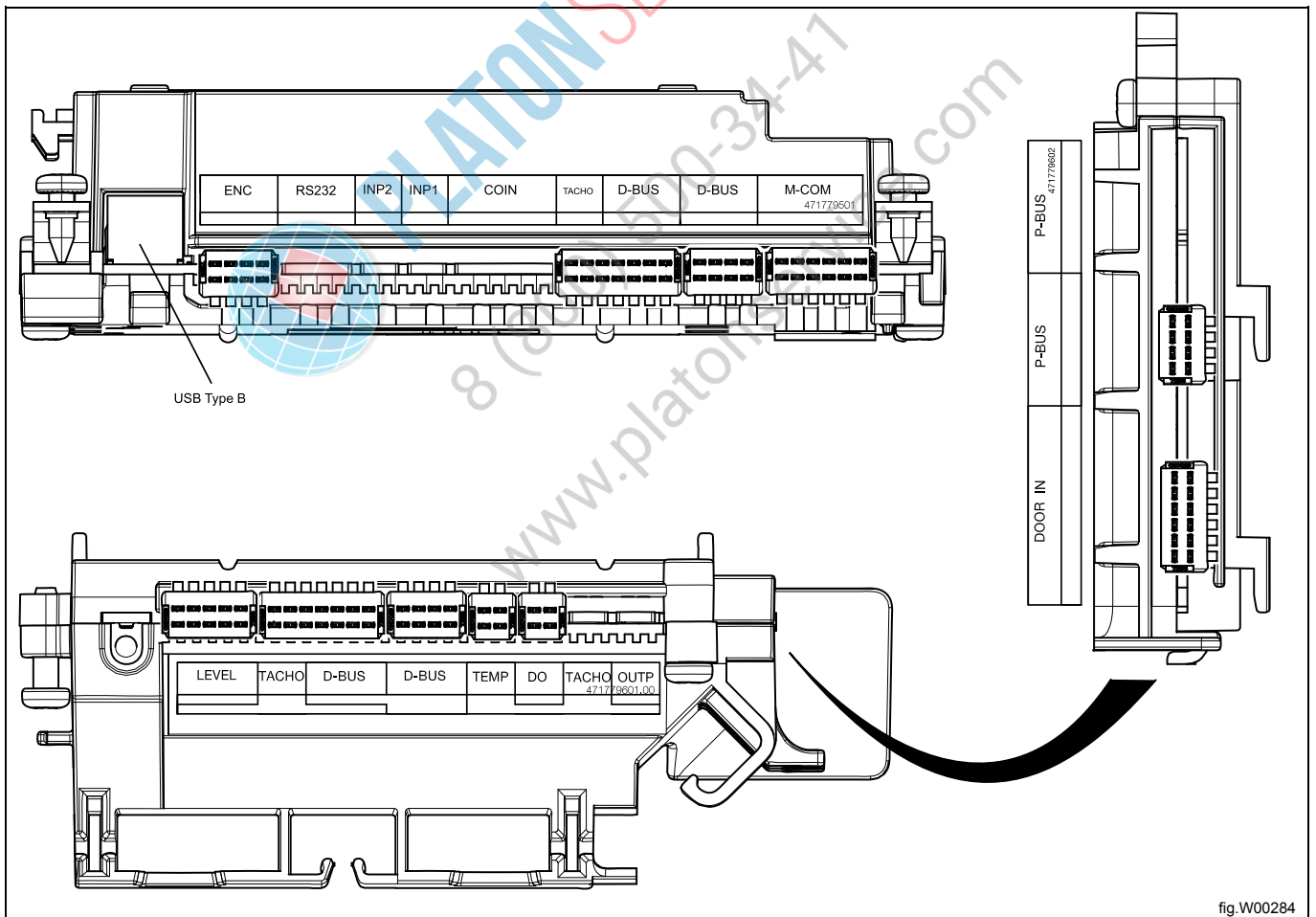

fig.W00284

### 11.1.3 Replacement of control system CPU

Disconnect the power to the machine.  
Demount the top panel.

#### Demount the control knob

Insert a screwdriver in the upper hole.

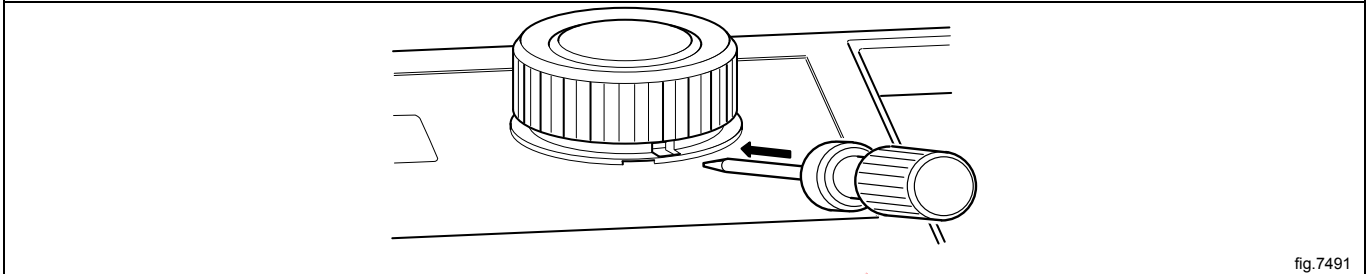

Gently push the screwdriver inwards and turn the control knob counter-clockwise until the screwdriver goes further in.

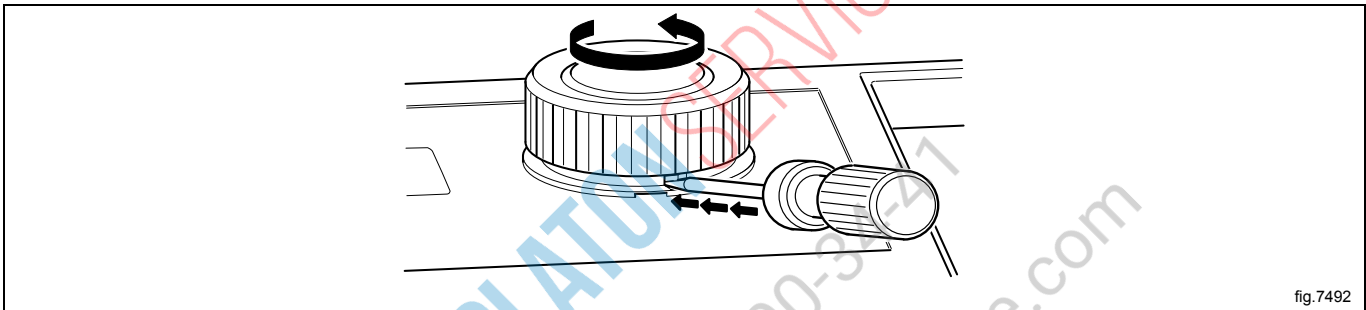

Continue turning a quarter of a turn until it is possible to remove the control knob.

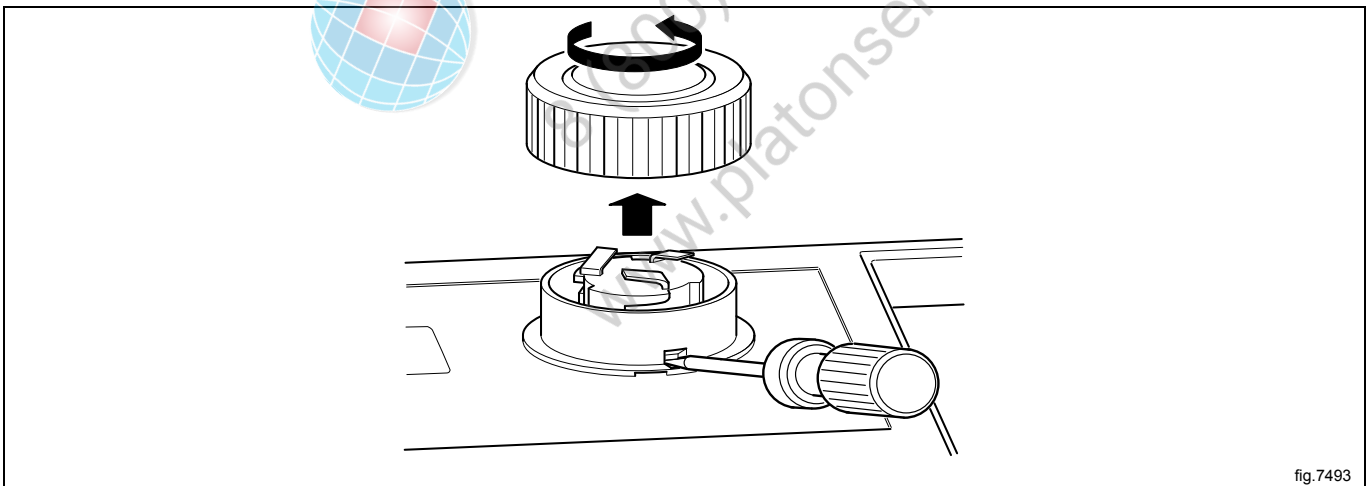

**Demount the cover ring**

When the control knob is removed, insert the screwdriver in the lower hole and press gently. Turn the cover ring counter-clockwise until it is possible to remove the cover ring.

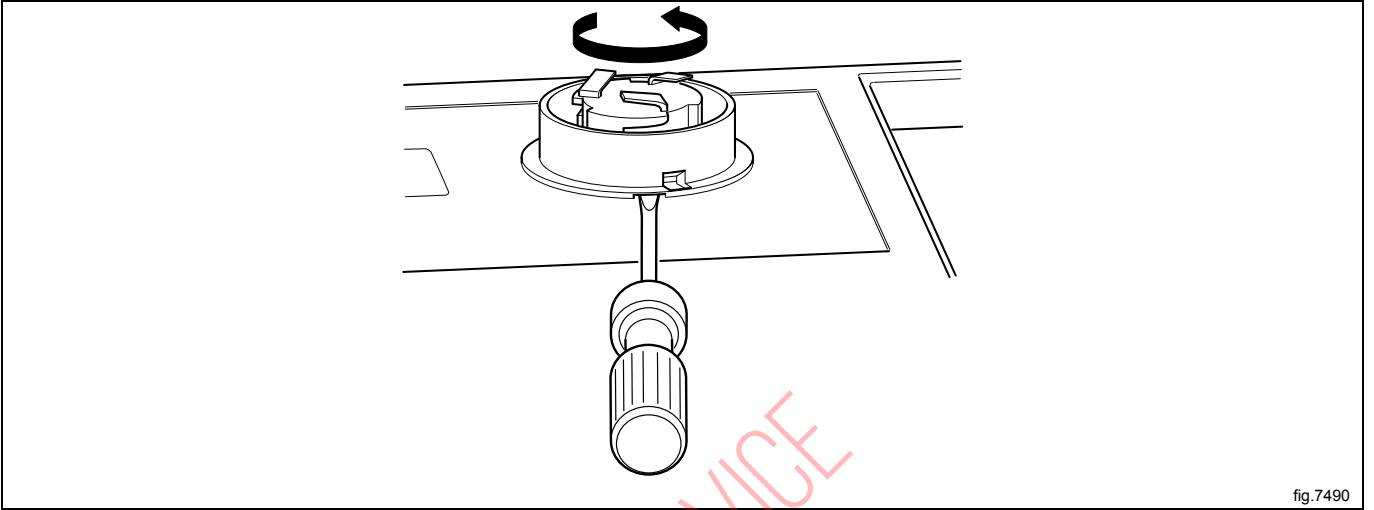

fig.7490

**Demount the control system CPU**

Demount the cover and disconnect the cables.

Loosen the screws holding the control system CPU onto the panel and demount the control system CPU.

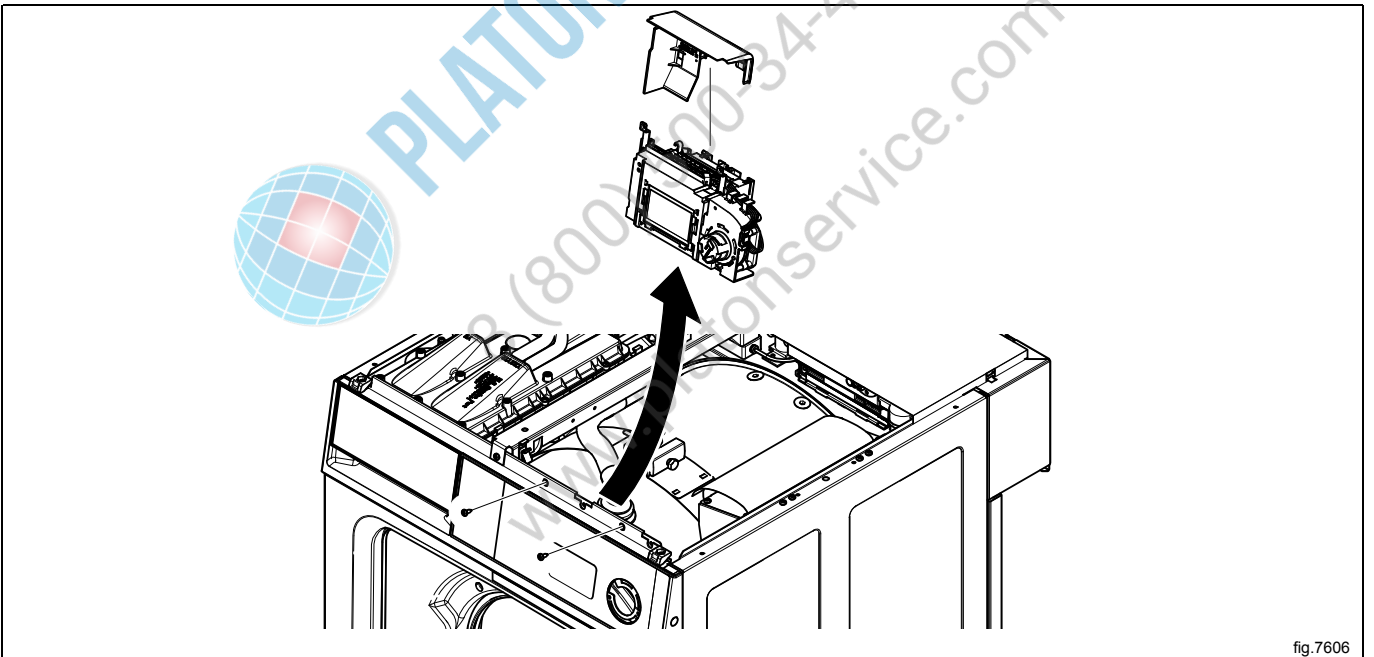
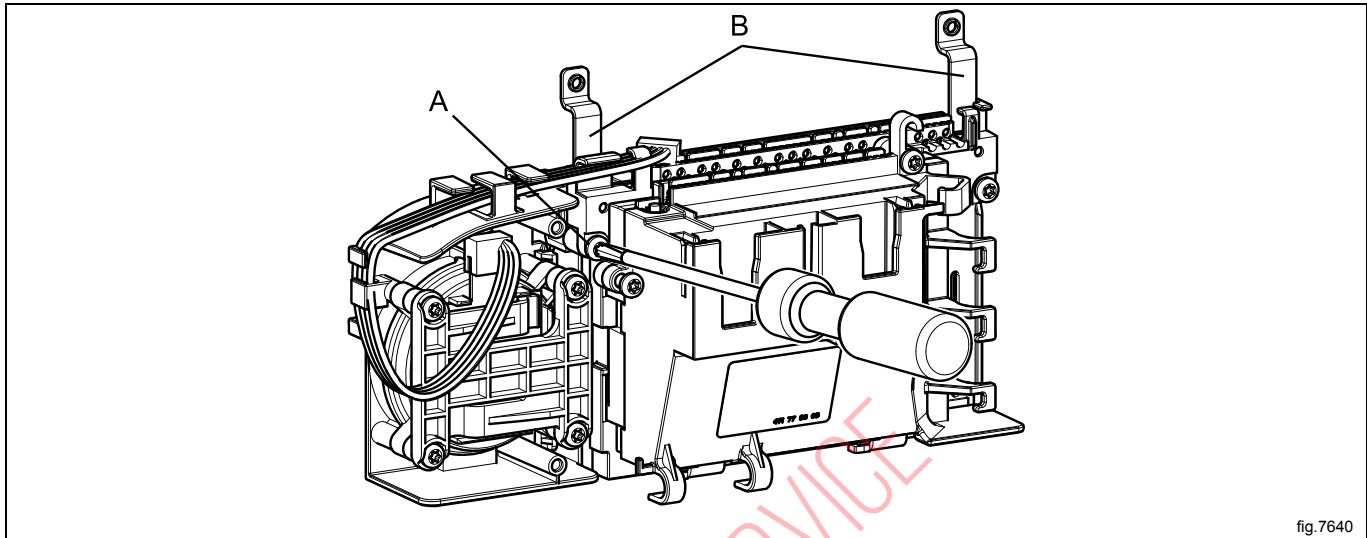

fig.7606

Demount the control knob unit from the control system CPU by unscrewing the screw (A) a bit (4–5 mm) until the control knob unit loosens.

Demount the two grounding brackets (B).



Demount the I/O module type 10 from the control system CPU by unscrewing the screw (C) a bit (4–5 mm). Remove the I/O module type 10 by lifting it upwards.

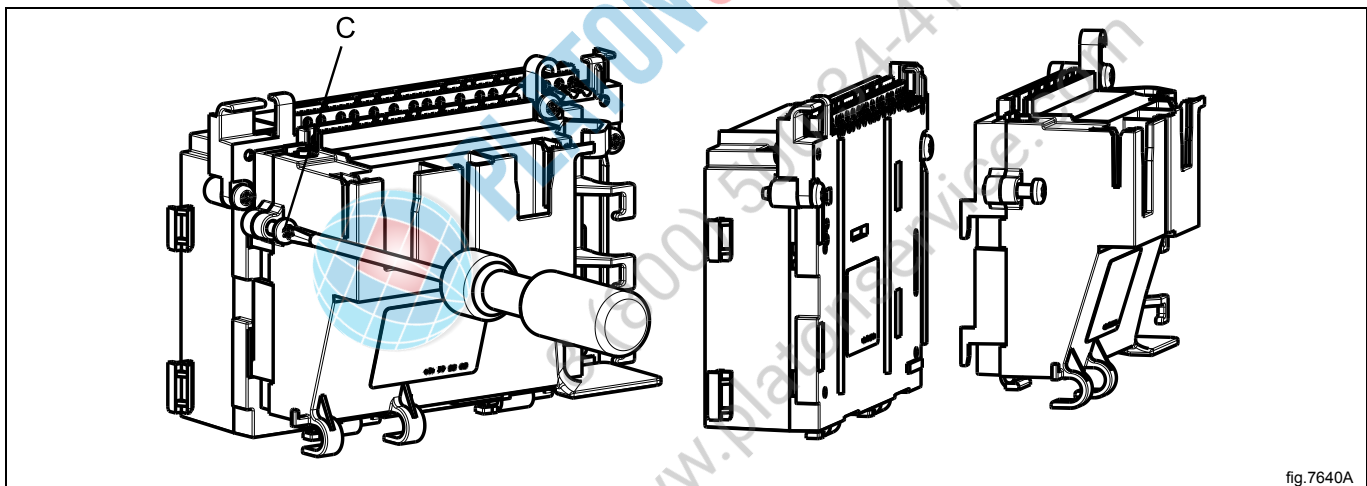

**Mount the new control system CPU**

Start by mounting the control knob unit on the control system CPU. Fasten the screw (A).

Mount the I/O module type 10 and fasten the screw (C).

Mount the two grounding brackets (B) on the new control system CPU.

Mount the control system CPU on the control panel and make sure that the guide pins (D) are in position. Fasten the screws to the panel.

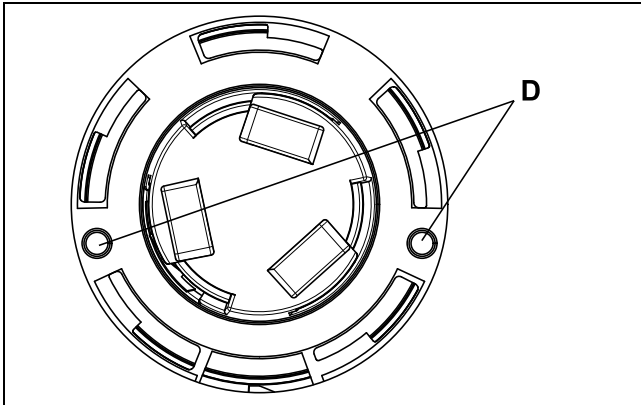

Connect the cables and remount the cover.

**Mount the cover ring and the control knob**

Mount the cover ring and rotate it clockwise until it is in position.

Rotate the inner knob until the locking device is pointing downwards.

Insert the screwdriver and press the locking device.

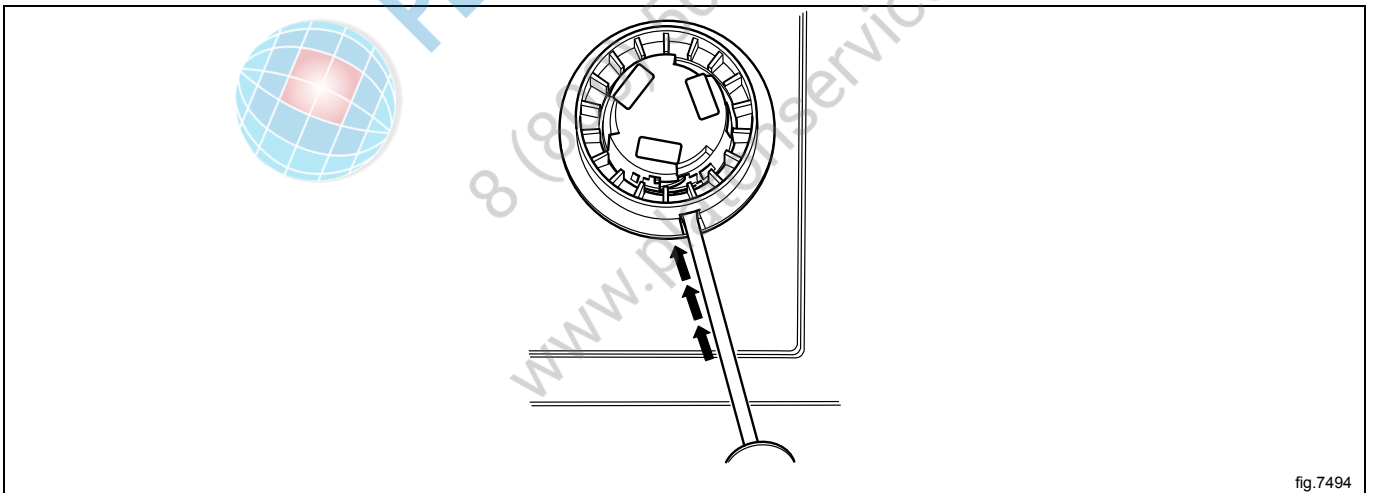

fig.7494

Mount the control knob on the inner knob. Continue to press with the screwdriver and turn the control knob clockwise until it stops when it is in position.

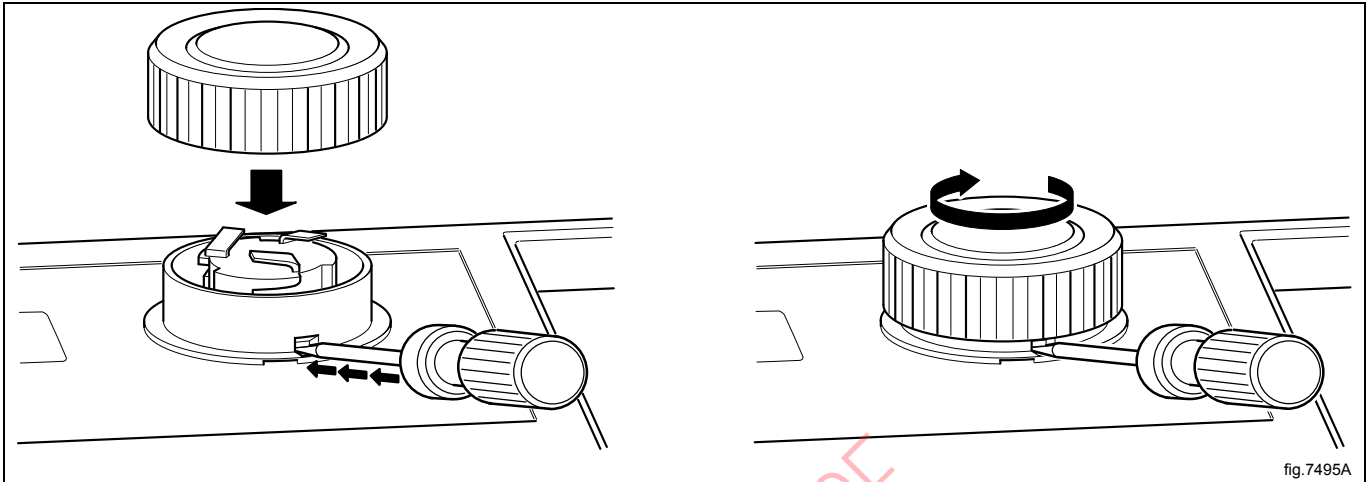

fig.7495A



**PLATON SERVICE**  
8 (800) 500-34-47  
[www.platonservice.com](http://www.platonservice.com)

## 11.2 Control knob

### 11.2.1 Replacement of control knob

Disconnect the power to the machine.

Insert a screwdriver in the upper hole.

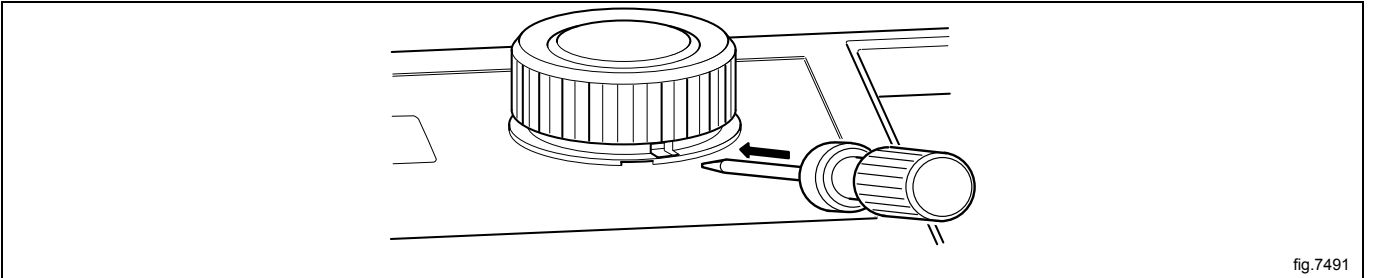

fig.7491

Gently push the screwdriver inwards and turn the control knob counter-clockwise until the screwdriver goes further in.

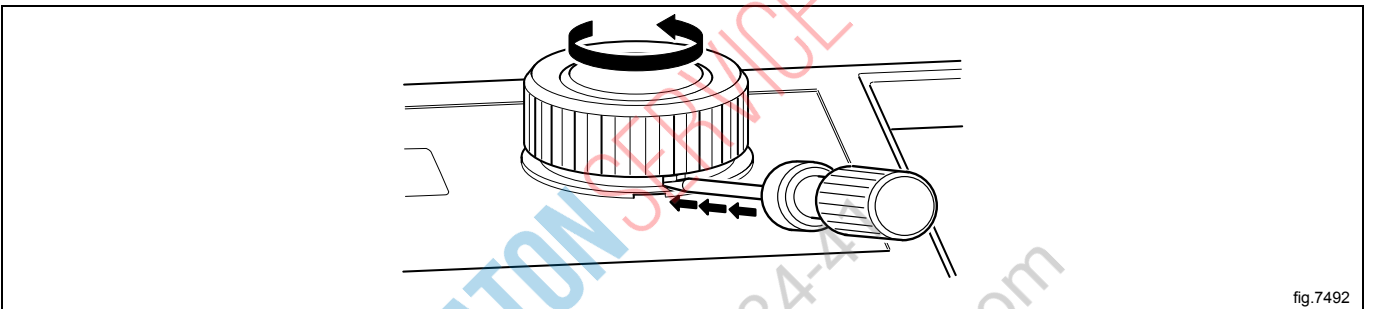

fig.7492

Continue turning a quarter of a turn until it is possible to remove the control knob.

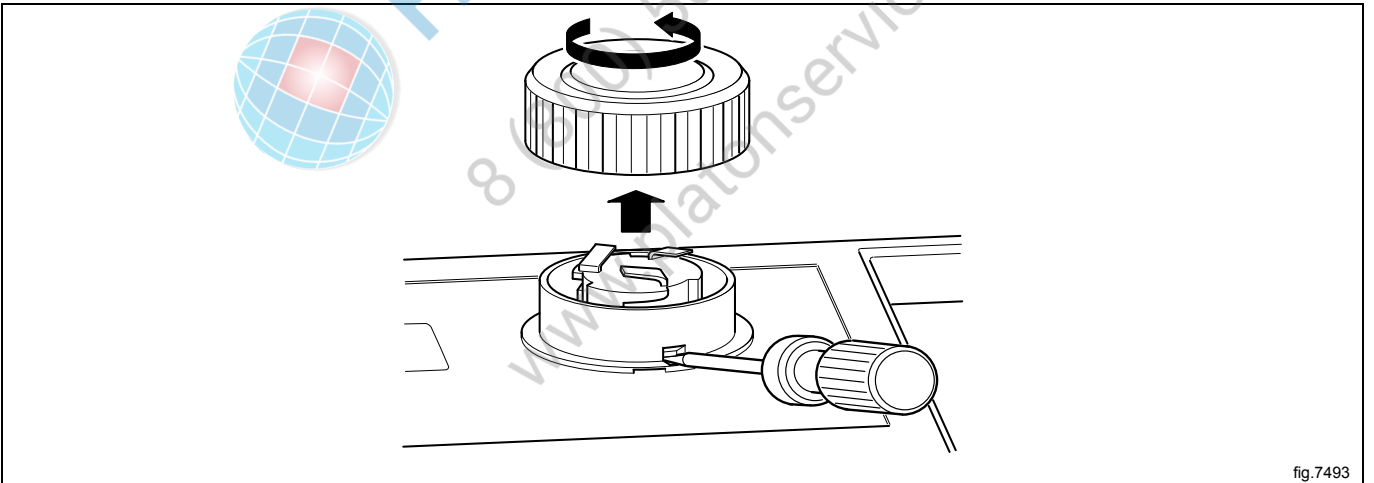
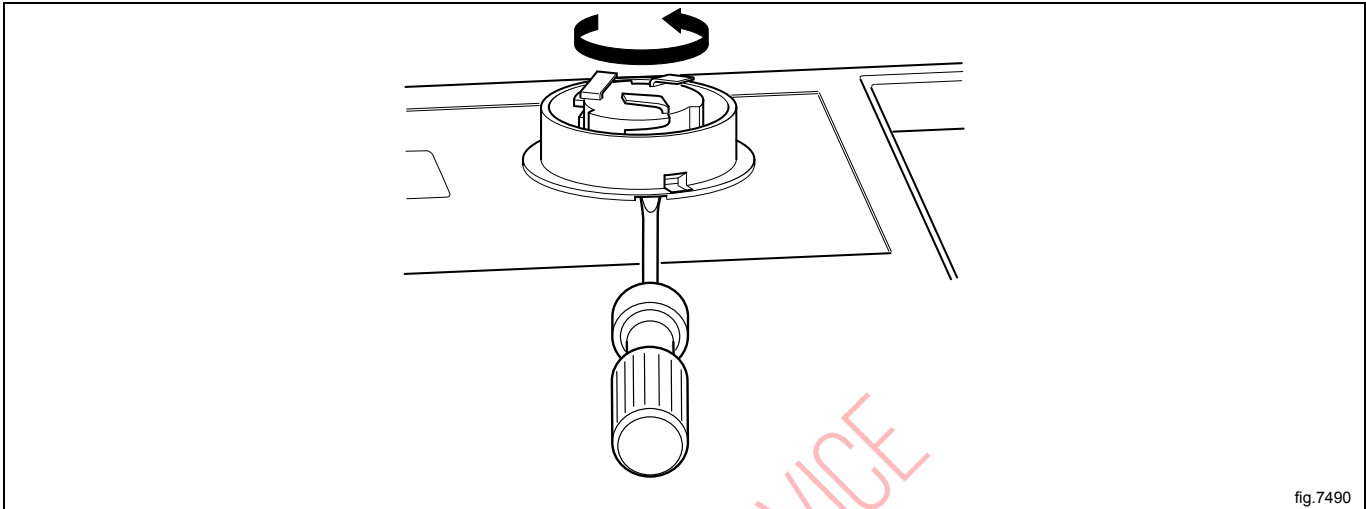

fig.7493

**Cover ring**

When the control knob is removed, insert the screwdriver in the lower hole and press gently. Turn the cover ring counter-clockwise until it is possible to remove the cover ring.



Mount the new cover ring and rotate it clockwise until it is in position.

Rotate the inner knob until the locking device is pointing downwards. Insert the screwdriver and press the locking device.

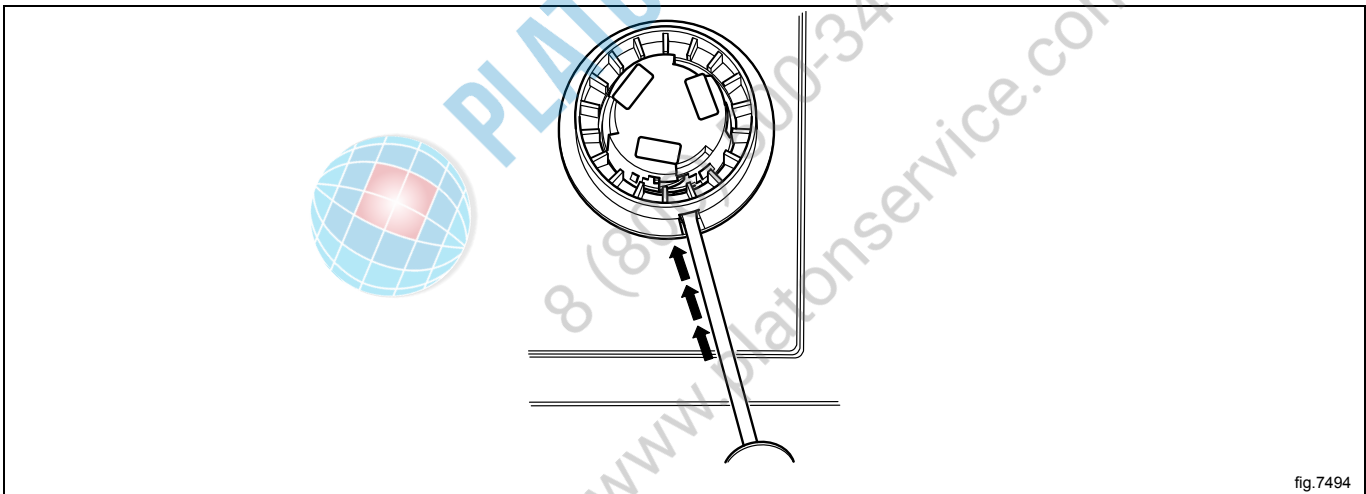



Mount the new control knob on the inner knob. Continue to press with the screwdriver and turn the control knob clockwise until it stops when it is in position.

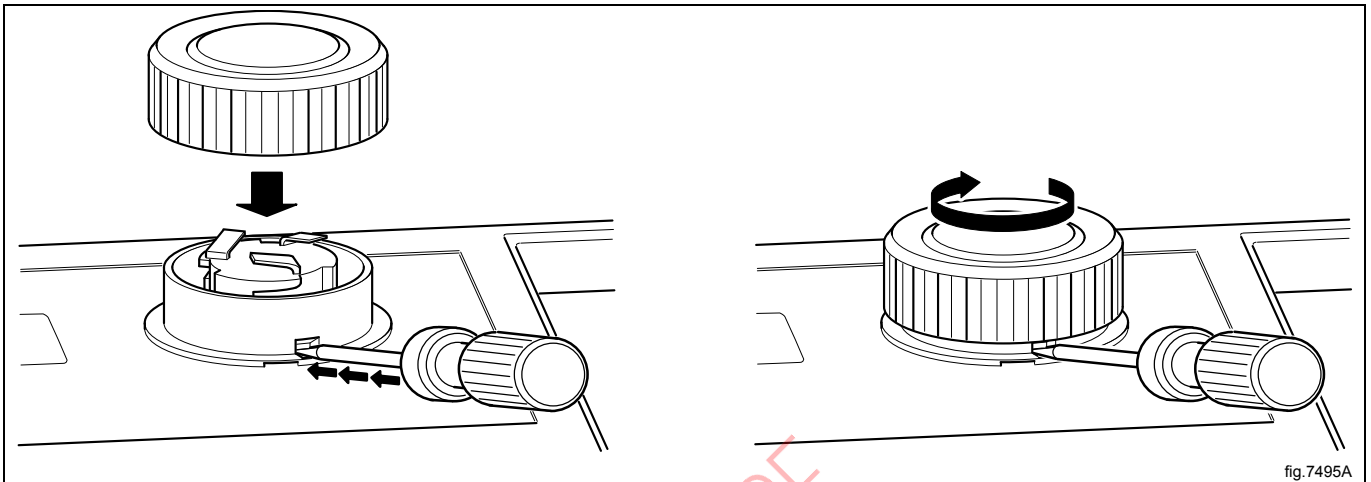

### 11.3 USB connection

To open the USB connection; use a screwdriver to carefully press and open the lid.

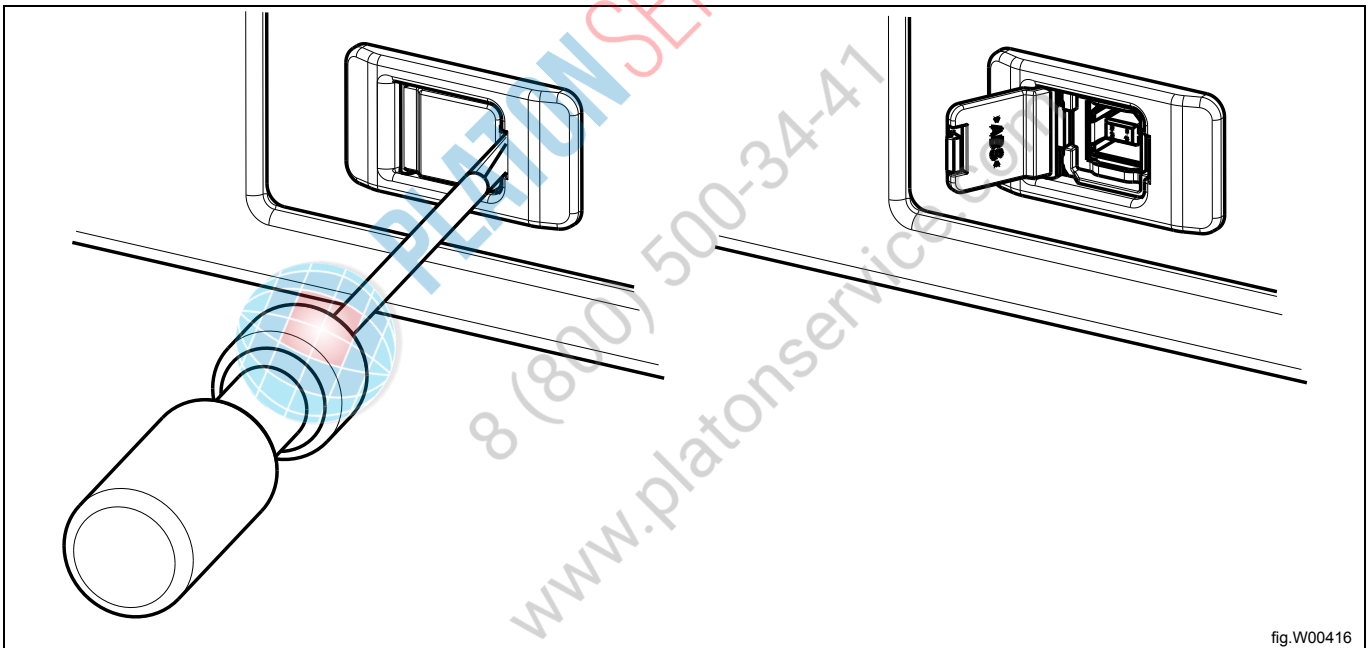

## 12 I/O modules

### 12.1 General

The machine can be equipped with either two or more I/O modules:

- I/O module type 1, 11 or 3 is always installed in the machine at delivery. It controls internal machine functions and outputs to heating, water valves, drain etc.
- I/O module type 10 is always installed in the machine at delivery. It controls the door lock functions.
- I/O module type 6 is always installed in the machine at delivery (except marine models). I/O module type 6, Power Balance, controls and handles the out-of-balance of the drum package during the entire extraction cycle.
- I/O module type 2 is installed as an option. It controls the external functions like detergent dosing systems and inputs from payment and booking systems etc.

The functionality of I/O module inputs and outputs is depending on the parameter software downloaded to the machine's control system. The function options for the I/O modules are indicated by a letter in the program designation for each module.

### Location

The parameter software installed in the machine's control system on delivery is specified at the front and back of the machine.

Using this article number, you can find the program designation and thereby identify I/O module function options on the web.

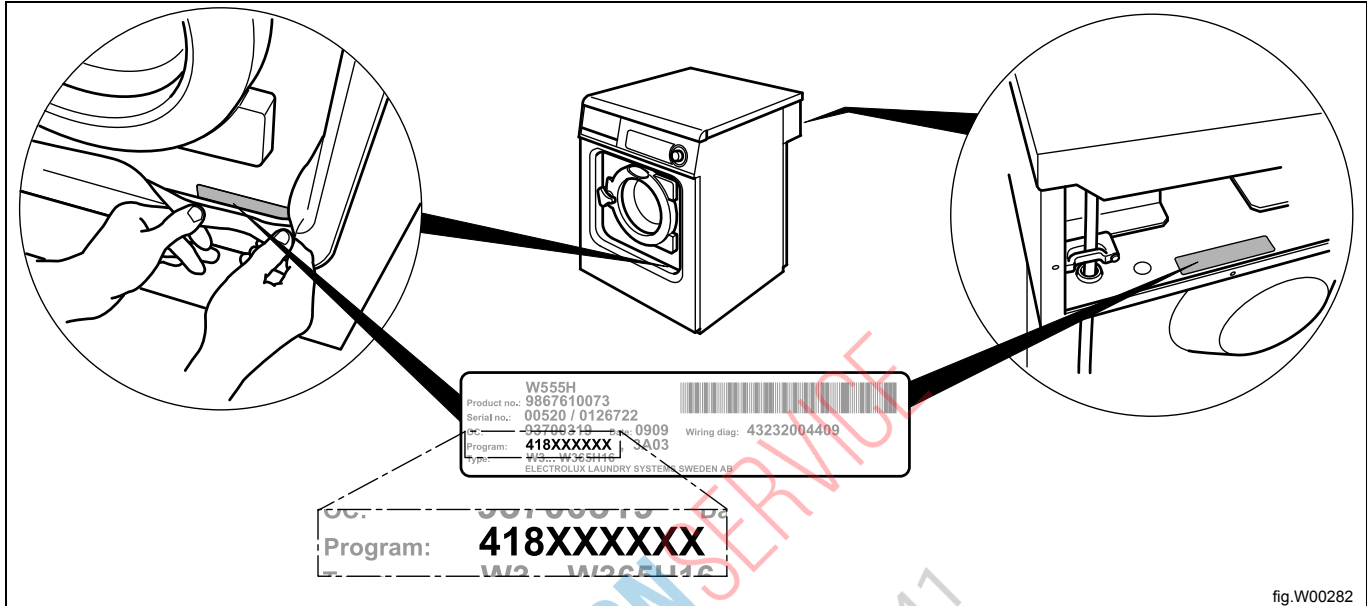

fig.W00282

## 12.2 Replacement of I/O module

### I/O module type 1, 11 or 3 and I/O module type 2

I/O module type 1, 11 or 3 and I/O module type 2 are installed in the same way. If the machine has I/O module type 2, it is located on I/O module type 1, 11 or 3. The illustration shows replacement of I/O module type 1.

Disconnect the power to the machine.

Demount the top panel.

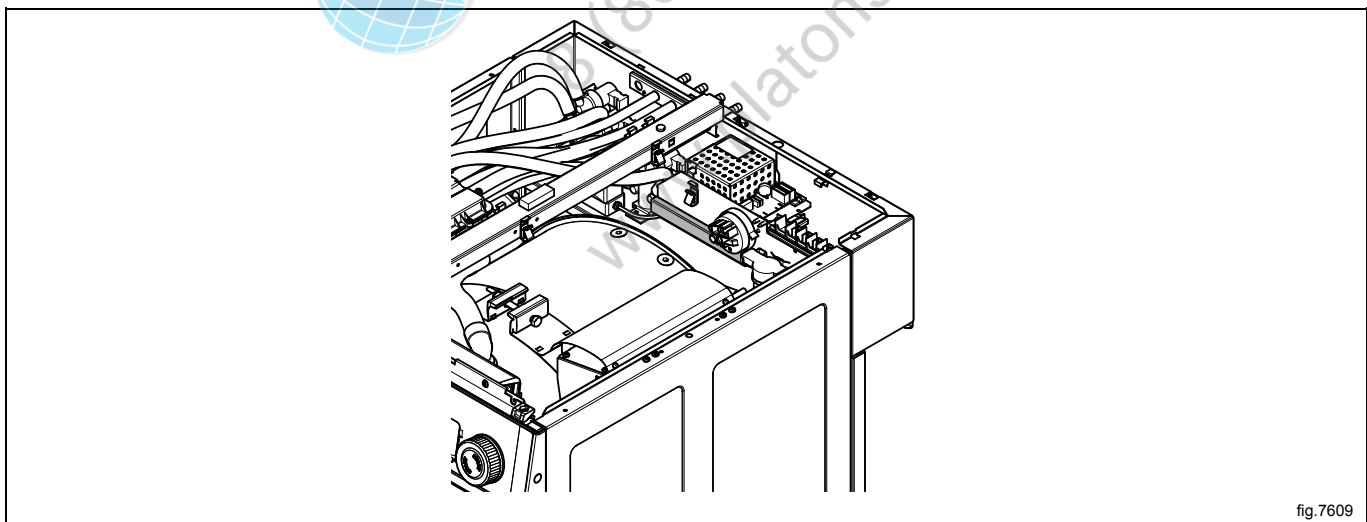

fig.7609

Remove the electrical connections on the module. (Note the position of the connections).  
 Remove the module by pulling it out towards the front of the machine.

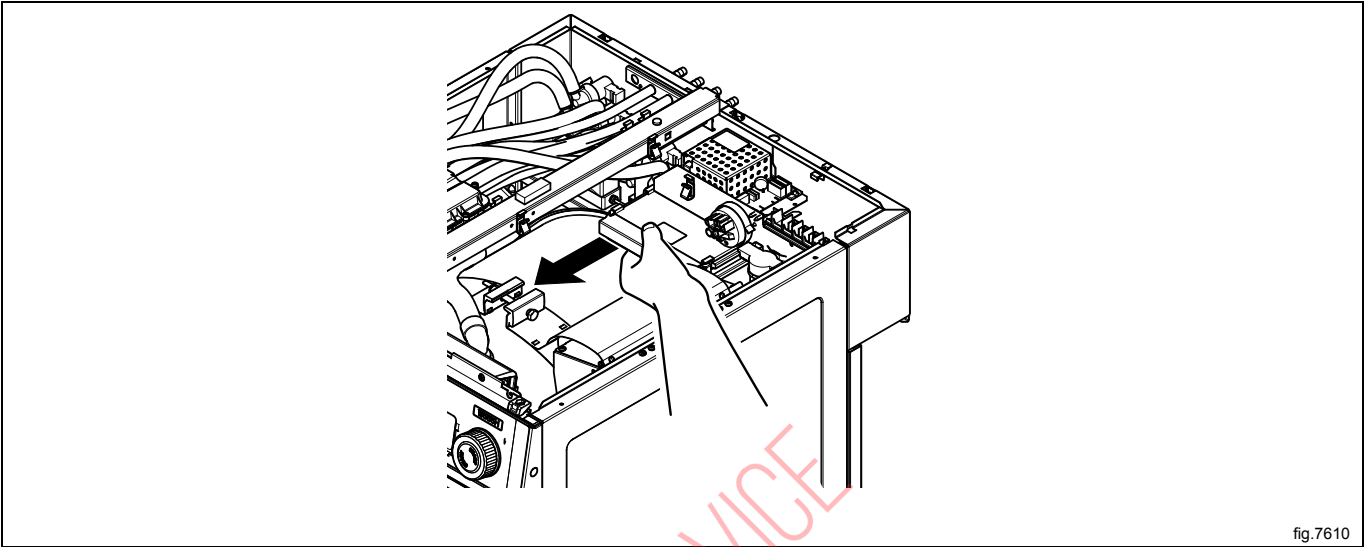

fig.7610

Insert the new module and make sure it is in position.  
 Connect the electrical connections in the same way as before.  
 If both I/O module type 1, 11 or 3 and I/O module type 2 is to be replaced it is recommended to fit the modules together before mounting in the machine.

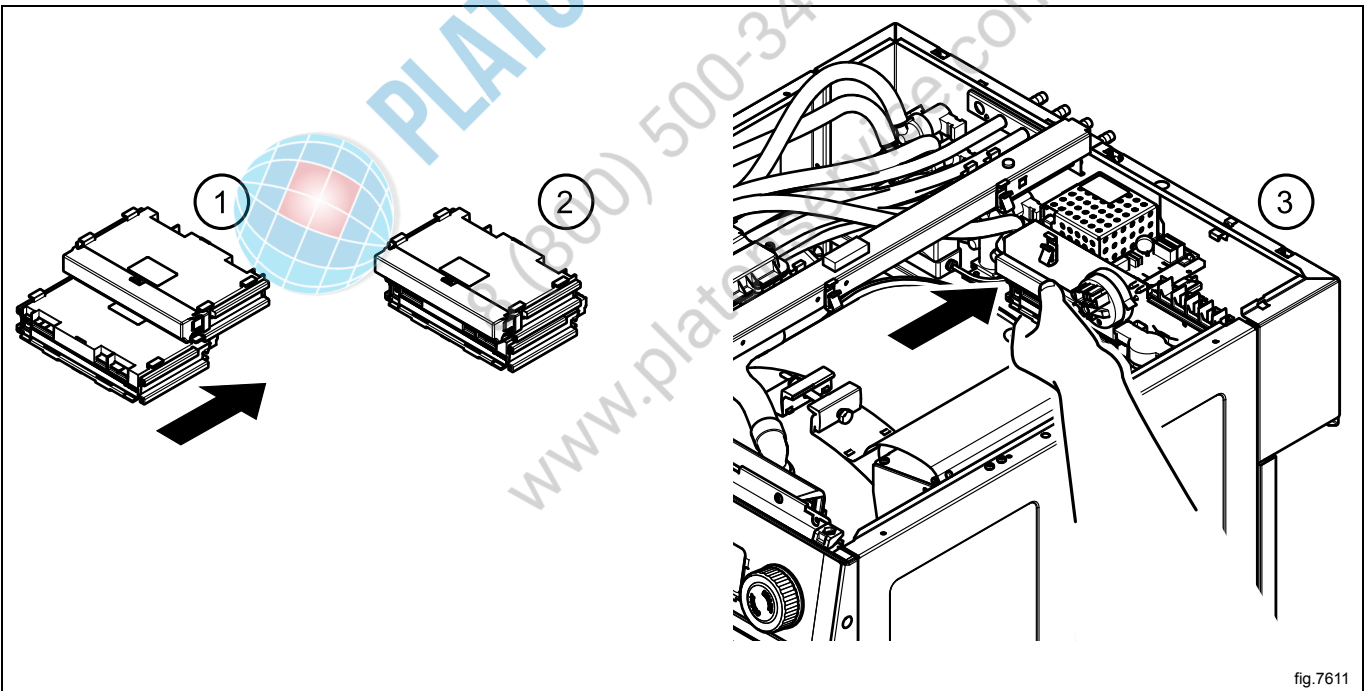

fig.7611

Remount the top panel.  
 Connect the power to the machine.

**I/O module type 10**

Disconnect the power to the machine.

Demount the top panel.

Remove the cover to the control system and I/O module type 10.

Remove the electrical connections on the module. (Note the position of the connections).

Loosen the screw (A) a bit and remove the I/O module by lifting it upwards.

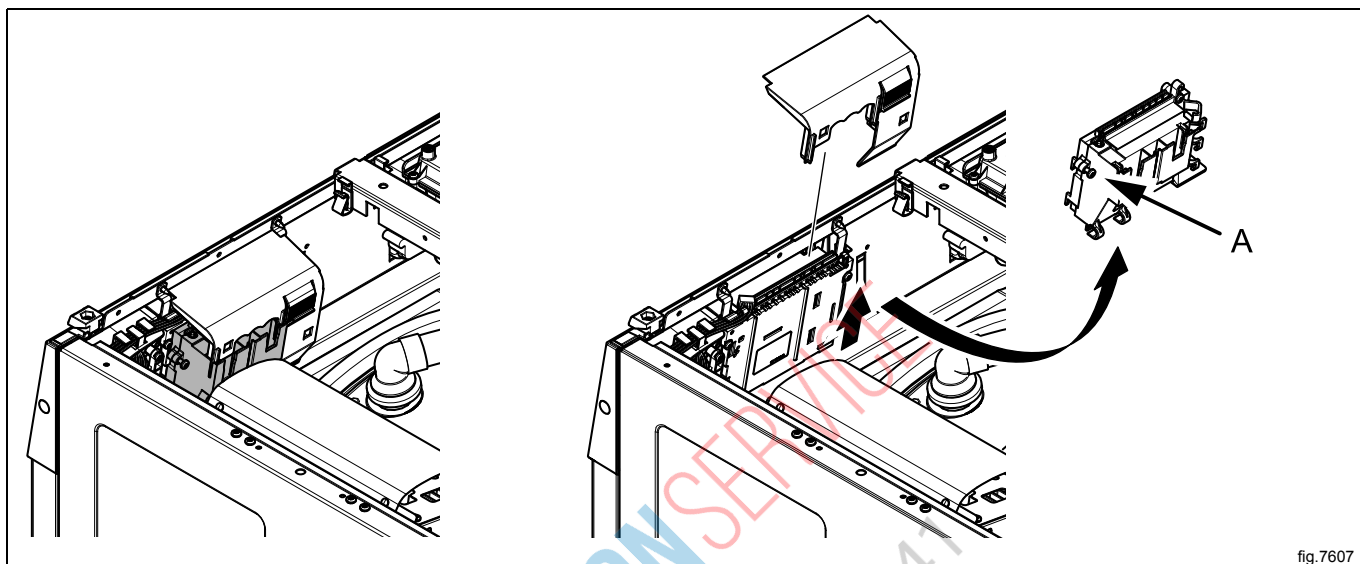

fig.7607

Insert the new module and make sure it is in position.

Connect the electrical connections in the same way as before.

Fasten the screw (A) and remount the cover.

Remount the top panel.

Connect the power to the machine.



8 (800) 500-34-41  
www.platonservice.com

**I/O module type 6**

Disconnect the power to the machine.

Demount the front panel.

Demount the door.

Demount the trim panel.

Disconnect the cable and demount I/O module type 6.

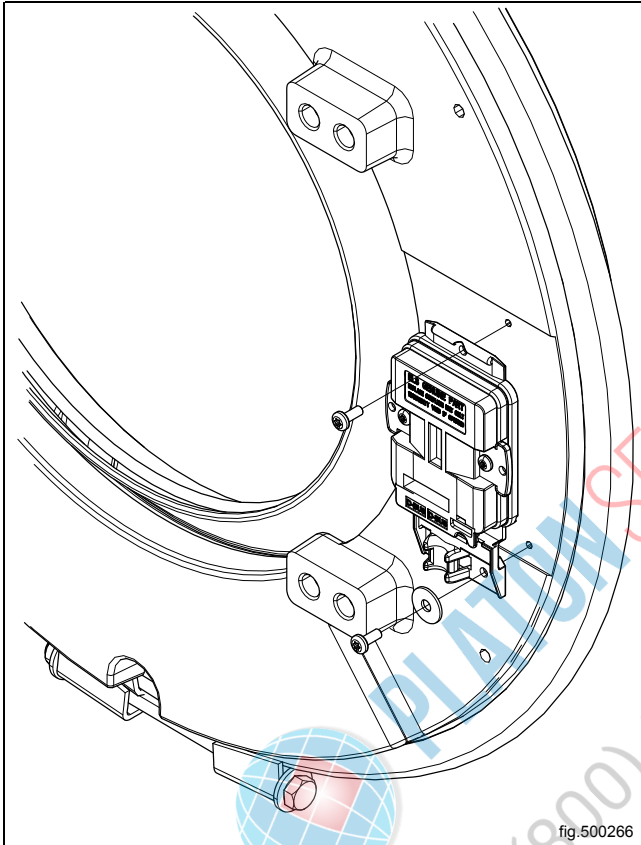

Mount the new module and make sure it is in position.

Connect the cable.

Mount the trim panel, the door and the front panel.

Connect the power to the machine.

### 12.3 External connections to I/O module type 2

#### Inputs

The signal level may be 5 - 24V DC/AC or 100 - 240V AC. At 5 - 24V, the signal reference must be connected to 3 and at 100 - 240V to 4.

#### Note!

Do not mix potentials on the inputs.

Connecting excessive voltage (> 24V) to connection 3 may damage the I/O modules.

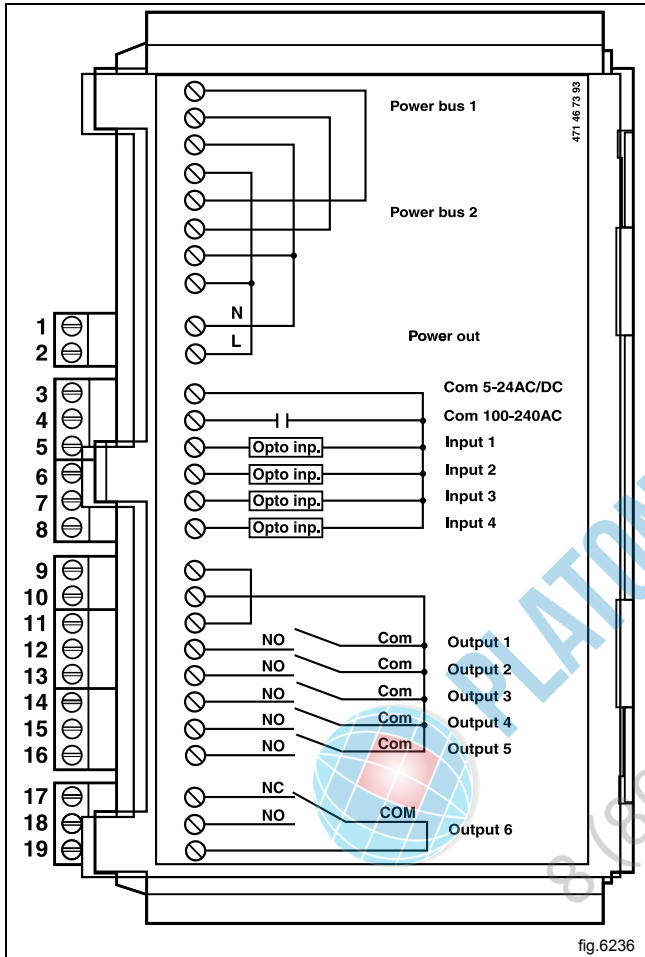

fig.6236

PLATON SERVICE  
8 (800) 500-34-47  
www.platonservice.com

## 12.4 Circuit diagram of function options for I/O module type 2

### 12.4.1 External coin meter/Central payment (2A)

The signal received from external coin meters must be a pulse between 300–3000 ms (500 ms is recommended) with a minimum pause of 300 ms (500 ms is recommended) between two pulses.

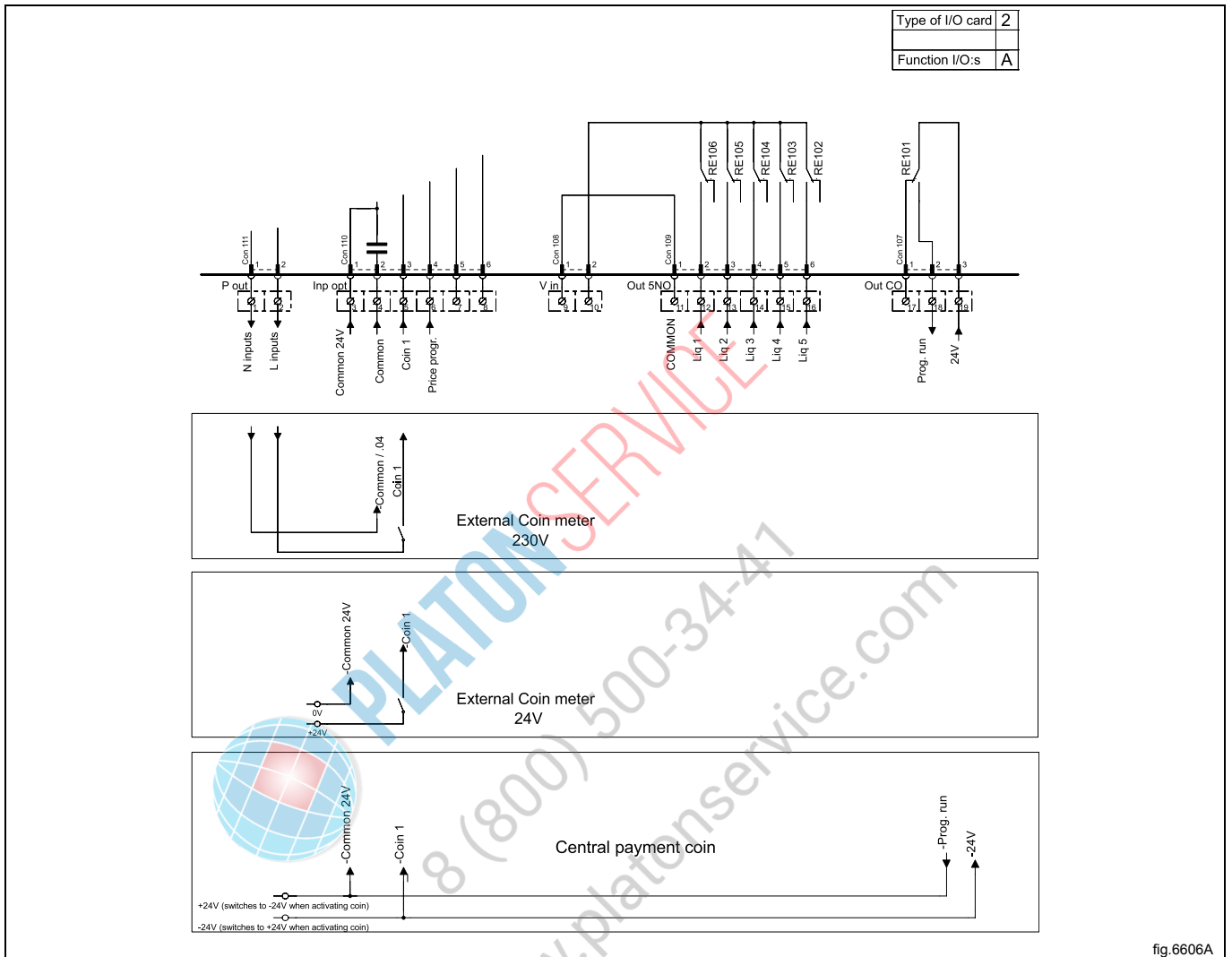

fig.6606A

### 12.4.2 Central payment (2B)

To start the machine from a central payment system, the payment system must transmit a start pulse to the machine. The start pulse can be either 230V or 24V. In order to receive a feedback signal once the machine has started, 230V or 24V must be connected to connection 19. The feedback signal on connection 18 remains active (high) during the entire program.

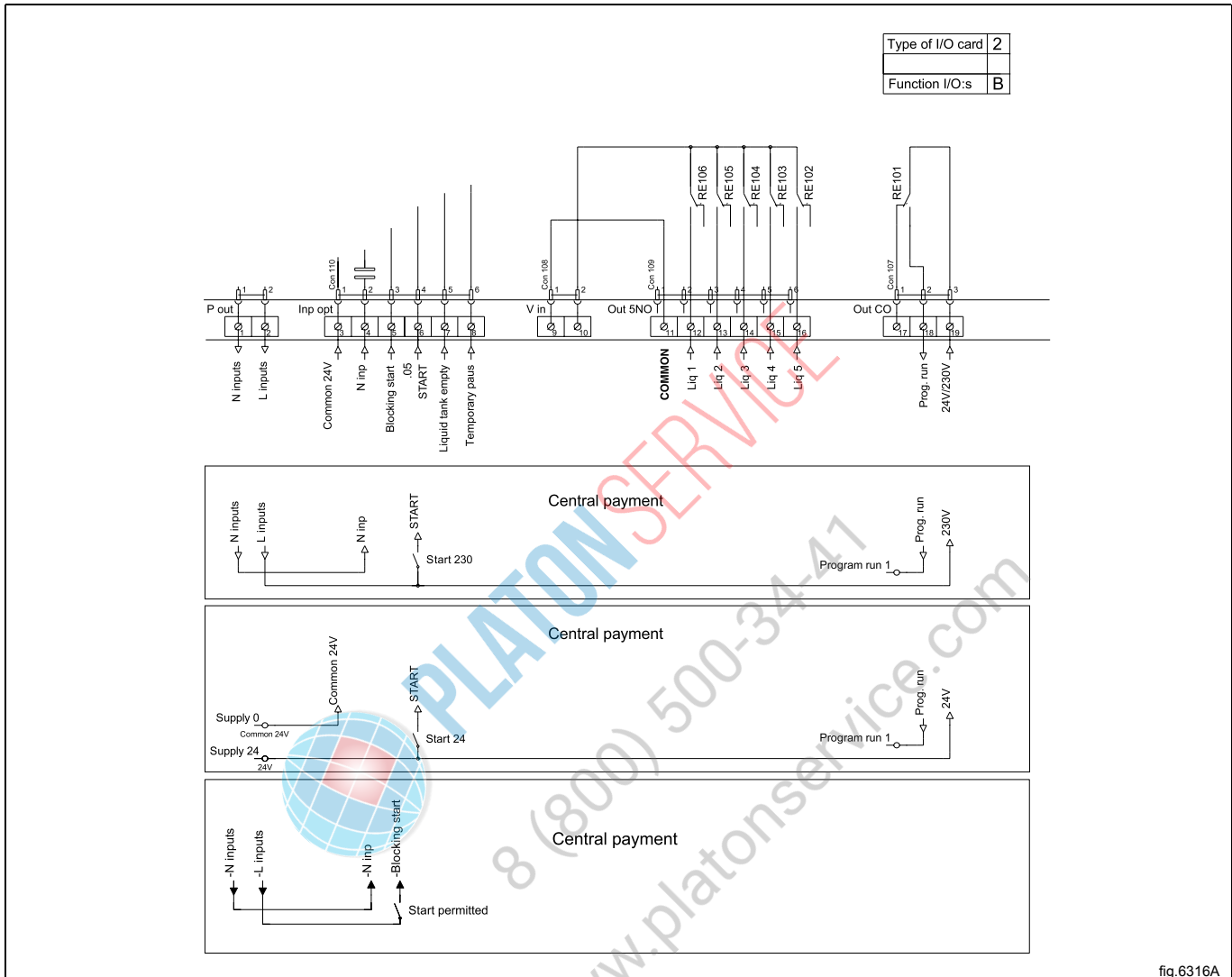

fig.6316A



### 12.4.3 Central payment (2C)

The central payment or booking system shall transmit an active (high) signal to the machine once permission has been granted to start the machine. The signal must remain active (high) until the machine starts. A feedback signal will be present on connection 18 and remain active (high) whilst the machine door is closed but the program has not started. The feedback signal is powered by 230V or 24V from connection 19.

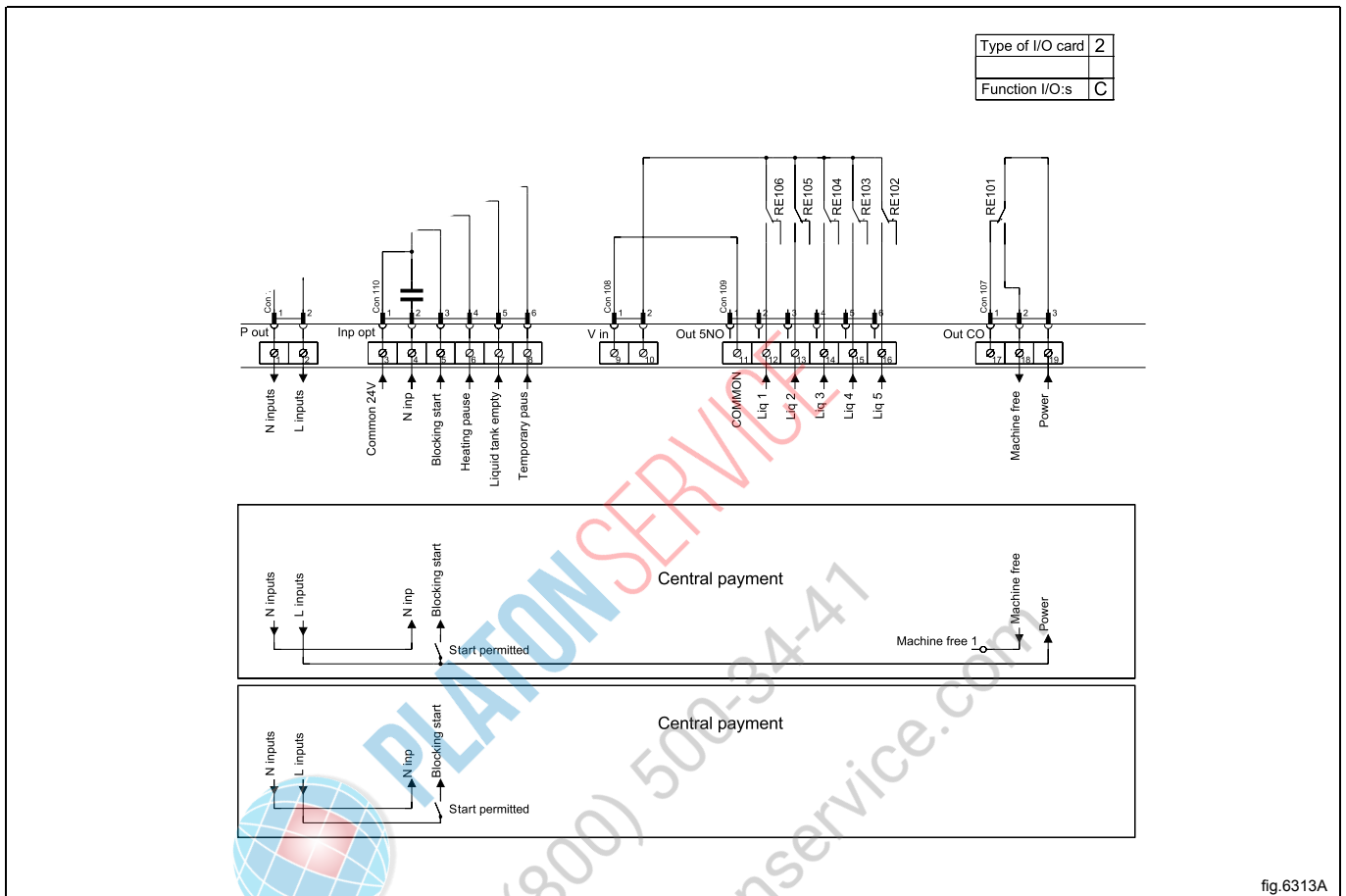
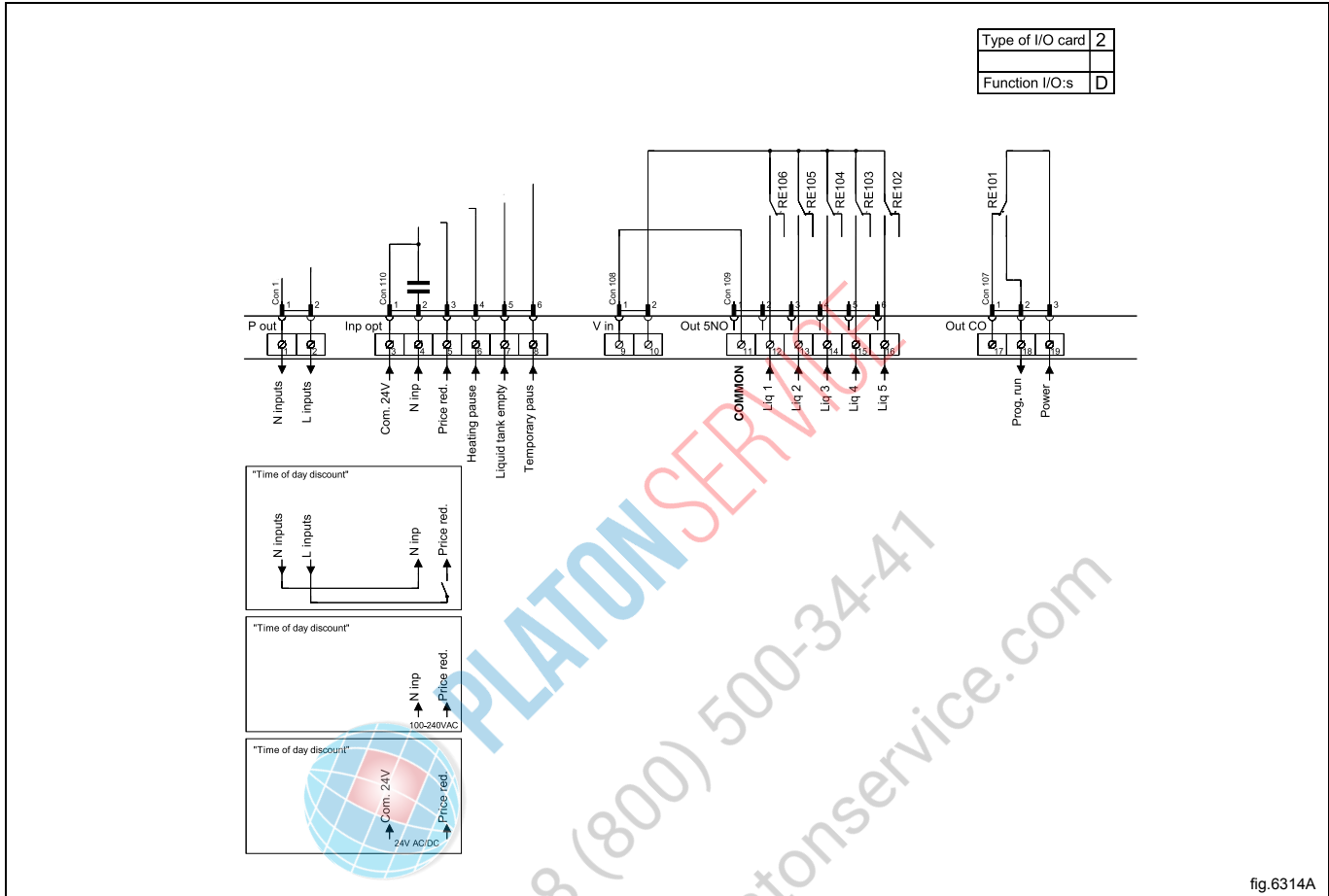

fig.6313A

### 12.4.4 Outputs for detergent signals and inputs for pause signals, "empty" signal and price reduction (2D)

The figure shows standard function addressing for machines with the coin program package.

By maintaining an active (high) signal on connection 5 ("Price red"), the price of the program can be reduced. This function has a number of uses, including providing reductions during a specific period of the day. Whilst the signal remains active (high), the price of the program is reduced by the percentage entered in the price programming menu.



### 12.4.5 Outputs for detergent signals and inputs for pause signals and "empty" signal (2E)

Heating pause: By connecting a signal to connection 6, you can pause operation of the machine whilst it heats up. The machine will pause for as long as the pause signal remains active (high).

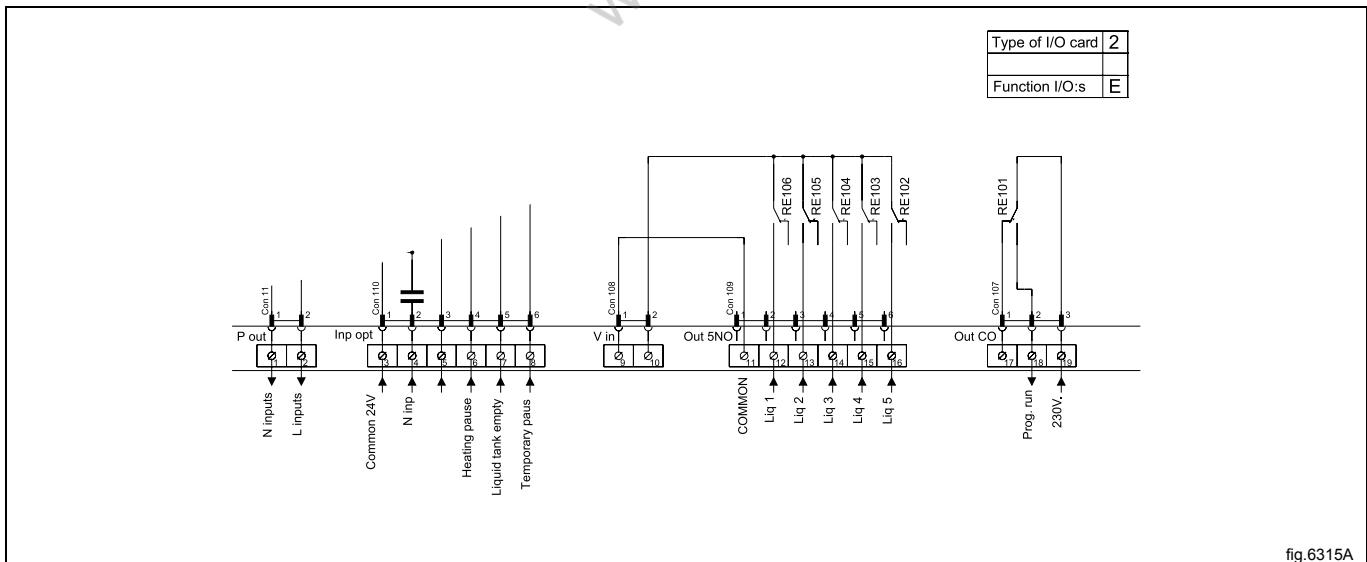

### 12.4.6 Central booking/payment (2F)

The central payment or booking system shall provide an active (high) signal to the machine once permission has been granted to start the machine. The signal must remain active (high) until the machine starts. A feedback signal will be present on connection 18 and remain active (high) whilst the program is running. The feedback signal is powered by 230V from connection 19 or external 24V.

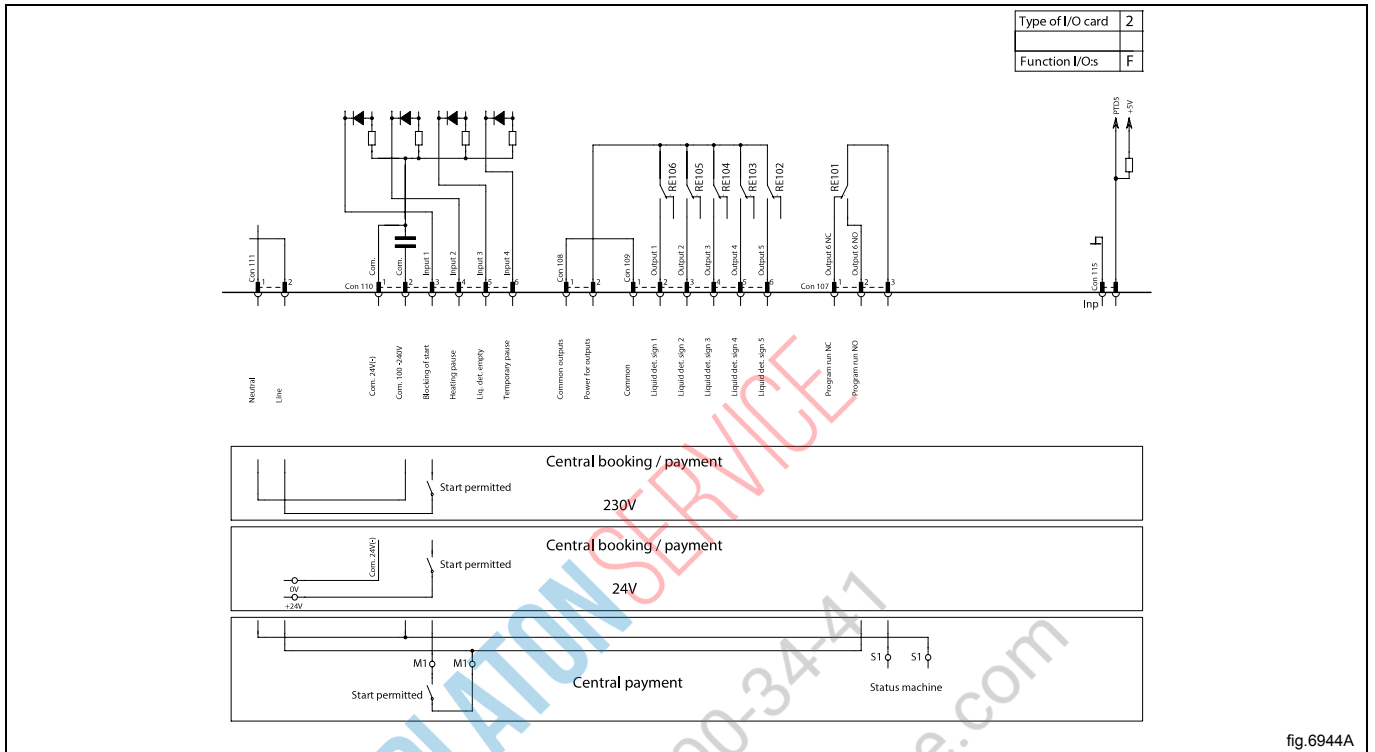

fig.6944A



8 (800) 500-34-41  
www.platonservice.com

### 12.4.7 Machines with I/O module type 3

By maintaining an active (high) signal on connection 3 "Price reduction", the price of the program can be reduced. This function has a number of uses, including providing reductions during a specific period of the day. Whilst the signal remains active (high), the price of the program is reduced by the percentage entered in the price programming menu.

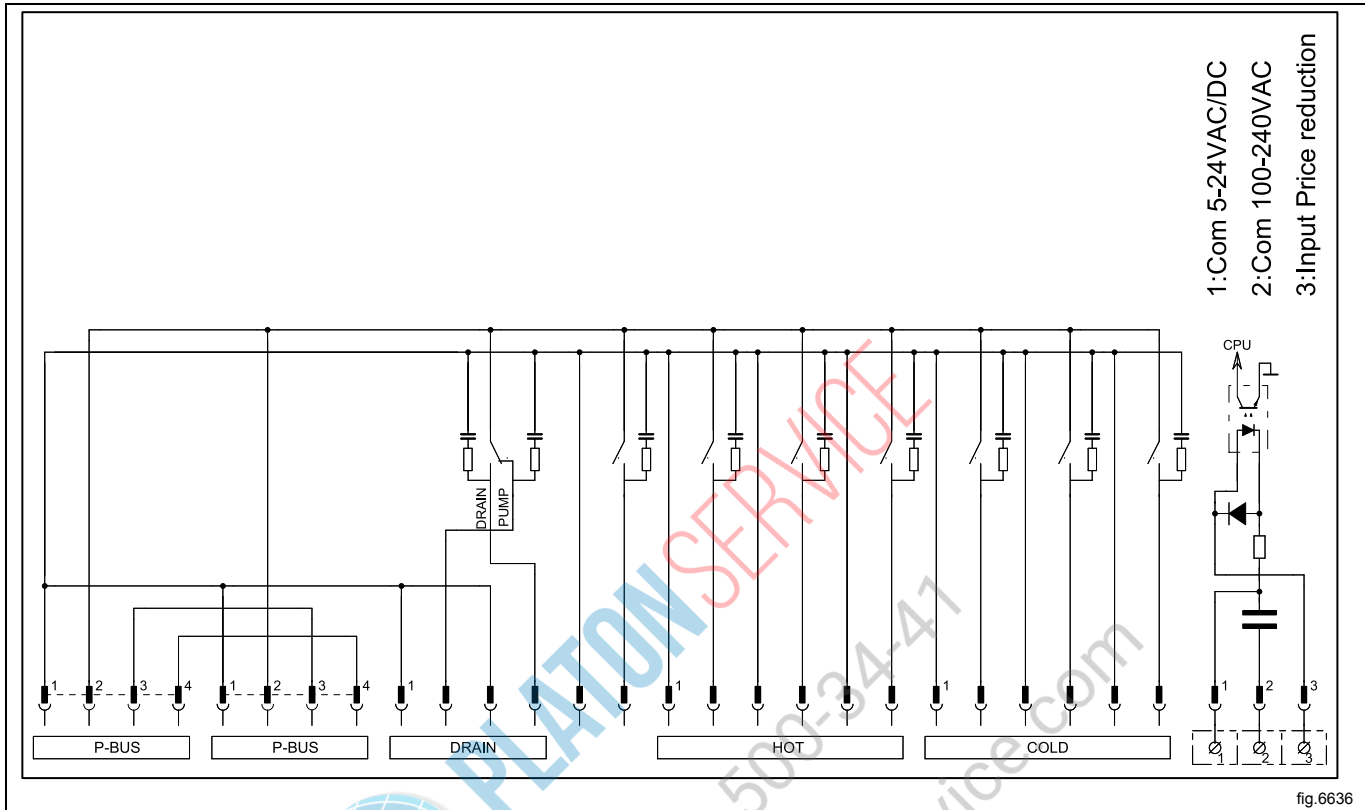

## 13 Troubleshooting

### 13.1 General

The troubleshooting section is used to trace errors in the machine to a defective component or unit.

There is a memory in the control system that will save the selected program for 10 minutes in the case of power failure. The machine will restart in pause mode if the power is turned on again within this time. For very short power failure (less than 10 seconds) the machine will restart automatically.



Before resetting any error code, always verify and correct the root cause why the error is triggered.

### Safety regulations

Troubleshooting may only be carried out by authorised personnel.

Take care during all work on the machine while the power is on.



Take care when measuring the motor control system since all components have a potential difference of approximately 300V in relation to protective earth and neutral. The components will contain dangerous voltages when the green LED on the motor control board is on. The motor control system will remain live for 30-60 seconds after cutting the power to the machine and the motor has stopped running.

## Measurements

For information on measuring points, components and voltages, please refer to the electric schematic supplied with the machine.



**PLATON SERVICE**

8 (800) 500-34-41

[www.platonservice.com](http://www.platonservice.com)

### 13.2 Error code

An error in the program or in the machine is indicated on the display by an error code and a descriptive text. The error codes are divided into different groups called "Major" comprising different error codes called "Minor". The errors will be displayed as for example 11 : 2 DOOR OPEN.

The following is a description of all Major groups followed by a description of each error code.

Error code		Text
Major	Minor	
10 MAIN COMMON	1	INTERNAL ERROR CPU TACHO
	11	REAL TIME CLOCK OUT OF ORDER
	13	INITIALIZING FAILED
	15	MACHINE STOP
	16	EMERGENCY STOP

Error code		Text
Major	Minor	
11 MAIN WASHER	1	NO WATER
	2	DOOR OPEN / LOADING DOOR OPEN
	3	DOOR LOCK FAIL / LOADING DOOR NOT LOCKED
	4	WATER LOW TEMP
	5	WATER HIGH TEMP
	6	WATER IN MACHINE AT PROGRAM END
	8	NO HEATING
	9	DRUM OVERFILLED
	10	MAX TIME DRAIN
	12	NO LEVEL SENSOR
	16	TIMEOUT HEATING
	17	DOOR LOCK
	27	LEVEL OFFSET
	28	WATER LEVEL HIGH DLCU LEVEL LOW
	29	WATER LEVEL LOW DLCU LEVEL HIGH
126	CO2 BOTTLE EMPTY	
127	DRAWER OUT CLOSE TO START	

Error code		Text
Major	Minor	
12 MAIN DRYER	1	O. H. THERMOSTAT - INLET AIR
	2	O. H. THERMOSTAT - OUTLET AIR
	3	INLET AIR SENSOR - OPEN
	4	INLET AIR SENSOR - SHORT CIRCUITED
	5	OUTLET AIR SENSOR - OPEN
	6	OUTLET AIR SENSOR - SHORT CIRCUITED
	8	CONDENSE WATER CONTAINER IS FULL
	9	HEAT PUMP LOW PRESSURE
	10	HP HIGH PRESSURE CHECK COOLING SYSTEM AND FILTERS
	11	DRYING ERROR WITH RMC PROGRAM
	12	DRYING ERROR WITH AUTOSTOP PROGRAM
	13	DRYING ERROR WITH TIME PROGRAM
	14	GAS ERROR PRESS GAS REST BUTTON
	15	NO VACUUM
	16	VACUUM SWITCH SHORTED
	17	AIRFLOW OBSTRUCTED MAINTENANCE NEEDED
	18	REDISTRIBUTION OF LOAD NEEDED
	253	JUMPER 1
	254	JUMPER 2
	255	JUMPER 3

Error code		Text
Major	Minor	
13 MAIN BARRIER	1	DRUM POSITIONING TIMED OUT
	2	DRUM LOCKING / UNLOCKING
	3	INNER DOOR OPENING
	4	INNER DOOR JACK POSITION
	5	DOOR UNLOCKING
	6	DRUM LOCK POSITION SWITCH
	7	DRUM NOT ROTATING
	8	UNBALANCE SWITCH ON AT PROG START
	9	WATER IN DRUM - CALL SERVICE
	10	WATER IN DRUM - CALL SERVICE
	11	UNLOADING DOOR NOT LOCKED
	12	LOADING DOOR NOT LOCKED
	13	UNLOADING DOOR NOT LOCKED
	14	INNER DRUM DOOR NOT CLOSED
	15	COMPRESSED AIR IS MISSING
	16	DRUM LOCK POSITION SWITCH

Error code		Text
Major	Minor	
14 MAIN W&D	1	EXTRACTION FAILED DRYING ABORTED

Error code		Text
Major	Minor	
15 MAIN POCKET	2	UNLOADING DOOR OPEN
	3	UNLOADING DOOR NOT LOCKED
	17	DOOR LOCK

Error code		Text
Major	Minor	
20 DRUM MOTOR COMMON	1	O.H. DRUM MOTOR
	2	NO MOTOR COMMUNICATION
	3	LOST MOTOR COMMUNICATION

Error code		Text
Major	Minor	
21 DRUM MOTOR EWD	1	HEATSINK TOO HOT
	2	MOTOR TOO HOT
	3	NO INTERLOCK
	4	NO COMMUNICATION
	5	MOTOR SHORT CIRCUIT
	6	INTERLOCK HARDWARE
	7	LOW DC VOLTAGE
	8	HIGH DC VOLTAGE
	12	NO PARAMET. SET IN MCU
	13	UNBALANCE
	15	MOTOR NOT FOLLOW
	255	UNDEFINED ERROR

Error code		Text
Major	Minor	
22 DRUM MOTOR KEB	0	SECURITY INPUT
	1	OVERVOLTAGE
	2	UNDervOLTAGE
	3	PHASE FAILURE
	4	OVERCURRENT
	6	OVERHEAT INTERNAL
	7	NO OVERHEAT INTERNAL
	8	OVERHEAT POWER MODULE
	9	DRIVE OVERHEAT
	11	NO DRIVE OVERHEAT
	12	POWER UNIT
	13	POWER UNIT NOT READY
	14	POWER UNIT INVALID
	15	LOAD SHUNT FAULT
	16	OVERLOAD
	17	NO OVERLOAD
	18	BUS
	19	OVERLOAD 2
	20	NO OVERLOAD 2
	21	EEPROM DEFECTIVE
	22	POWER UNIT COMMUNICATION
	23	BUS SYNCHRON.
	30	MOTOR PROTECTION
	31	EXTERNAL FAULT
	32	ENCODER 1
	33	POWER FACTOR CONTROL
36	NO OVERHEAT POWER MODULE	
39	SET	
46	PROTECT. ROT. FORWARD	
47	PROTECT. ROT. REVERSE	
49	POWER UNIT CODE INVALID	

Error code		Text
Major	Minor	
23 DRUM MOTOR OBIWAN	1	HEATSINK TOO HOT
	2	MOTOR TOO HOT
	3	NO INTERLOCK
	4	NO COMMUNICATION
	5	MOTOR SHORT CIRCUIT
	6	INTERLOCK HARDWARE
	7	LOW DC VOLTAGE
	8	HIGH DC VOLTAGE
	255	UNDEFINED ERROR

Error code		Text
Major	Minor	
30 FAN MOTOR COMMON	1	O. H. FAN MOTOR

Error code		Text
Major	Minor	
40 INTERNAL COM.	1-10	I/O INTERLOCK Axxx
	11-20	I/O COMMUNICATION Axxx
	21	I/O COMMUNICATION
	22	I/O BOARD MISMATCH



Error code		Text
Major	Minor	
41 INTERNAL COM. I/O TYPE 10	1	CHARGE CIRCUIT
	2	SET SIGNAL, NO TACHO. WAIT 5 MINUTES
	3	ACTUATOR CIRCUIT
	21	CHARGE CIRCUIT
	22	SET SIGNAL, NO TACHO. WAIT 5 MINUTES
	23	ACTUATOR CIRCUIT

Error code		Text
Major	Minor	
42 INTERNAL COM. I/O TYPE 6	1	I/O TYPE 6 INTERNAL ERROR
	2	I/O TYPE 6 POSITION TEST
	3	I/O TYPE 6 EXTRACT TEST

Error code		Text
Major	Minor	
51 EXTERNAL COM. PAYMENT	22	NO CBT COMMUNICATION PRESS TO RETRY

Error code		Text
Major	Minor	
52 EXTERNAL COM. MIS	1	CMIS COMMUNICATION ERROR
	2	DMIS COMMUNICATION ERROR

Error code		Text
Major	Minor	
60 INTERNAL	5	FATAL ERROR INVALID RUNNING MODE
	11	FATAL ERROR EXTERNAL FLASH WRITE
	17	FATAL ERROR INVALID OPTION
	18	FATAL ERROR INVALID MODULE
	28	FATAL ERROR INVALID COIN INPUT
	29	FATAL ERROR INVALID FONT

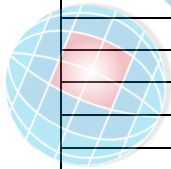

PLATON SERVICE

8 (800) 500-3447  
www.platonservice.com

### 13.3 Description of error codes and causes

#### MAIN COMMON

##### 10:1 INTERNAL ERROR CPU TACHO

Tacho input on CPU delivers values that is out of range.

Recommended actions:

1. Run motor on highest possible speed in service mode. Check input value for RPM speed.
2. Replace defective component.

##### 10:11 REAL TIME CLOCK OUT OF ORDER

The real time clock is used by the control system for delayed start, measuring time, power failure, error codes, etc.

Upon power on, the communication with the internal real time clock in the control system is established. In case this fails, this error occurs

Recommended actions:

1. Power off the machine for 1 minute and try again.

##### 10:13 INITIALIZATION FAILED

The error code is shown if the hardware initialization has failed to initialize within 15 seconds after power on.

Recommended actions:

1. Press the control knob/start button to retry.
2. Upload a new software that matches the machine configuration and try again.

##### 10:15 MACHINE STOP

This message is shown if input for MACHINE STOP is activated.

This is not an error code but is handled in the same way.

Recommended actions:

1. Reset the Machine Stop Button.
2. Press the control knob to confirm machine stop. Machine will revert to Idle mode.

##### 10:16 EMERGENCY STOP

This message is shown if input for EMERGENCY STOP is activated. This is not an error code but is handled in the same way.

Recommended actions:

1. Reset the Emergency Stop Button.
2. Press the control knob to confirm emergency stop. Machine will revert to Idle mode.

## MAIN WASHER

### 11:1 NO WATER

This error is shown if the programmed water level is not reached within a certain time, typically 10 minutes.

Max. filling time is defined in Config. 1 parameter `MAX FILL TIME`.

This error message can be turned off in Configuration - Error code.

Possible causes:

Long filling times can be caused by a leaking drain valve, blocked filler valve, defective filler valve, defective valve control board, clogged level sensor hose, leaking level system, etc.

Recommended actions:

1. Check for leaking drain valve by filling water to high level in service program.
2. Check for leaking or clogged level sensor system by filling water to high level in service program and then actual level in inputs.
3. Check for malfunction or block filler valve by activating input by input in service program.
4. Monitor a program by using Process viewer in ELS Common Service Tool.

### 11:2 DOOR OPEN / LOADING DOOR OPEN

This error code will be shown if the control system detect that the input `DOOR CLOSED` has been deactivated during an on-going program. This error code can only occur during an on-going program.

Possible causes:

This can be caused by for example a bad or defective door lock, loose cable to door lock, problem with door lock edge connection, defective input on I/O unit type 10 etc.

Recommended actions:

1. Check door lock functionality in service program, but activating door lock and then by checking inputs.
2. Check electrical connections by reading inputs at the same time as cables carefully moved/pulled.
3. Carefully knock on the door lock to locate intermittent errors.

### 11:3 DOOR LOCK FAIL / LOADING DOOR NOT LOCKED

This error code will be shown if the control system have not detected the input `DOOR LOCKED` to be active within a certain time after program start, typically 3 seconds.

Possible causes:

This can be caused by a mechanical problem preventing door lock to lock, defective door lock, loose cable connection to door lock, broken cables to door lock or mechanical problem with emergency opening of the door.

Recommended actions:

1. Check door lock functionality in service program, but activating door lock and then by checking check inputs.
2. Check electrical connections by reading inputs at the same time as cables carefully moved/pulled.
3. Carefully knock on the door lock unit to locate intermittent errors.
4. Check DLCU status in service mode for more information on possible causes.

### 11:4 WATER LOW TEMP

This error code is shown if the temperature sensor indicates temperature below approx.  $-9^{\circ}\text{C}/15^{\circ}\text{F}$ . Minimum allowed temperature is defined in Config. 2 parameter `MIN PROG TEMP`.

Possible causes:

This low temperature means that the resistance in the sensor is too high ( $>23.5\text{k}\Omega$  on all machines except Barrier Washers) or too low ( $<97\Omega$  on Barrier washers). This can be caused by, for example, the machine has been stored outdoors, or an open circuit in the sensor or its wiring (all machines except Barrier Washers) or short circuit in the sensor or its wiring (Barrier Washers).

Recommended actions:

1. Measure resistance in temperature sensor and check for open circuit or short circuit in its wiring. The resistance should be as shown in the table below:  
Temp - Resistance  
 $15^{\circ}\text{C} / 59^{\circ}\text{F}$  -  $7.6\text{ k}\Omega$  ( $105,9\Omega$  on Barrier)  
 $20^{\circ}\text{C} / 68^{\circ}\text{F}$  -  $6.0\text{ k}\Omega$  ( $107,8\Omega$  on Barrier)  
 $25^{\circ}\text{C} / 77^{\circ}\text{F}$  -  $4.8\text{ k}\Omega$  ( $109,7\Omega$  on Barrier)
2. Monitor a program by using Process viewer in ELS Common Service Tool to detect intermittent errors.

### 11:5 WATER HIGH TEMP

This error code is shown if the temperature sensor indicates temperature above + 98°C/208°F. Maximum allowed temperature is defined in Config. 2 parameter `MAX PROG TEMP`.

Possible causes:

This high temperature means that the resistance in the sensor is too low (< 350Ω on all machines except Barrier Washers) or too high (>137Ω on Barrier washers). This can be caused by, for example, short circuit in the sensor or its wiring (all machines except Barrier Washers) or an open circuit in the sensor or its wiring (Barrier Washers).

Recommended actions:

1. Measure resistance in temperature sensor and check for open circuit or short circuit in its wiring. The resistance should be as shown in the table below:

Temp - Resistance

15°C / 59°F - 7.6 kΩ (105,9Ω on Barrier)

20°C / 68°F - 6.0 kΩ (107,8Ω on Barrier)

25°C / 77°F - 4.8 kΩ (109,7Ω on Barrier)

Monitor a program by using Process viewer in ELS Common Service Tool to detect intermittent errors.

### 11:6 WATER IN MACHINE AT PROGRAM END

This error code will only appear at program end.

Error is activated if the level system has not indicated "empty drum" within a certain time, typically 3 minutes.

This error code can also arise if the program is rapid advanced to the end, or if program is aborted.

Maximum allowed drain time can be changed in Config. 2 parameter `MAX DRAIN TIME`.

Level for empty drum is defined in Config. 2 parameter `LEVEL EMPTY`.

This error message can be turned off in Configuration - Error code.

Possible causes:

- Clogged drain
- Foam/ clogged drain pipe
- Incorrect installation of drain pipe/drain system
- Defect drain valve
- Open water valve, filling water

Recommended actions:

1. Check drain for dirt.
2. Blow through the level hose and check that it is not blocked and does not contain any water.
3. Check in the service program that the level control is working correctly.
4. Check for detergent overdosing/remains of foam.
5. Make sure the installation of the drain system follows the installation manual for the machine.
6. Monitor a program by using Process viewer in ELS Common Service Tool.

### 11:8 NO HEATING

This error code is shown if the temperature is increasing too slowly when heating is active. The limit for this error code is normally set to a water temperature increase of approximately 3°C per 10 minutes but can vary depending on the type of machine and software.

Minimum temperature increase is defined in Config. 2 parameter `MIN TEMP INCREASE`.

Maximum heating time is defined in Config. 2 parameter `MAX HEATING TIME`.

This error message can be turned off in Configuration - Error code.

Possible causes:

This error code can be caused by for example a defective heating element, a break in the power supply to the heating element, defective heating contactor, leaking drain/refill of water, to low water level in program etc.

It can also occur in installations using power control, where number of machines that can heat at the same time is limited.

Recommended actions:

1. Check heating elements and electrical power to heaters.
2. Fill up water in service program, activate heat and monitor level and temperature increase.
3. Check for a leaking drain.
4. Monitor a program by using Process viewer in ELS Common Service Tool.

### 11:9 DRUM OVERFILLED

This error code is shown if the mechanical level sensor connected to input `DRUM OVERFILLED` detects a high level (used primary in W&D machines)

Possible causes:

This error code can be caused by for example water inlets not closing correctly, faulty level switch, blocked level hose, drops of water in the level hose, foam in drum or level hose, etc.

Recommended actions:

1. Check in the service program that all the water valves are working correctly.
2. Check that the level switch is working correctly. Switch is normally closed.
3. Blow through the level hose and check that it is not blocked and does not contain any water or foam.

### 11:10 MAX TIME DRAIN

This error code will only occur in drain or extraction modules.

Error is activated if the level system has not indicated "empty drum" within a certain time (approximately 3 min). This time may vary depending on the size of the machine.

Maximum allowed drain time is defined in Config. 2 parameter `MAX DRAIN TIME`.

Level for empty drum is defined in Config. 2 parameter `LEVEL EMPTY`, (may not be changed unless agreed with factory since it affects other functionality as well).

Recommended actions:

1. Check drain for dirt.
2. Blow through the level hose and check that it is not blocked and does not contain any water.
3. Check in the service program that the level control is working correctly.
4. Check for detergent overdosing/remains of foam.
5. Make sure the installation of the drain system follows the installation manual for the machine.
6. Monitor a program by using Process viewer in ELS Common Service Tool.

### 11:12 NO LEVEL SENSOR

This error code is activated if the CPU detects that there is no electronic level sensor connected.

It can also be caused by a broken cable to the sensor or a broken sensor.

### 11:16 TIMEOUT HEATING

This error code will be shown if total heating time in a program is longer than a Maximum allowed heating time, typically 2h 30 min.

Maximum allowed heating time is defined in Config. 2 parameter `HEATING TIMEOUT`.

Compared to Error code 11:8 - `NO HEATING`, this error code measures the maximum allowed heating time.

Possible causes:

Could occur if machine heats properly (min. temperature increase during heating is OK), but there is a drain leakage causing repeated fillings.

### 11:17 DOOR LOCK

This error code is shown if the input for `DOOR LOCKED` is active at program start, i.e. the door is locked although the control system has not requested locking.

Recommended actions:

1. Check door lock functionality in service program, by activating door lock and then by checking inputs.
2. Check DLCU status in service mode for more information on possible causes.
3. If DLCU is in error mode, wait five minutes for automatic reset or manually reset the DLCU in service mode.

### 11:27 LEVEL OFFSET

This error code is shown at program start if the level sensor indicates a level above what the control system CPU can compensate for. If high level is indicated a attempt is made to first drain the machine.

Maximum allowed level offset is defined in Config. 2 parameter `MAX LEV . ZERO OFFS.`

The drain time before error code is triggered is defined in Config. 2 parameter `MAX DRAIN TIME START.`

Possible causes:

This error can be caused by defective level control, blocked drain, blocked level hose, a drop of water in the level hose, etc.

Recommended actions:

1. Check in the service program that the level control is working correctly.
2. Blow through the level hose and check that it is not blocked and does not contain any water.
3. Check drain for dirt.

### 11:28 WATER LEVEL HIGH DLCU LEVEL LOW

The DLCU on I/O type 10 contains a mechanical DLCU level switch which ensures that there is no water in the machine when the door unlocks. To ensure that the DLCU level switch functions correctly, the DLCU level switch status is compared with a predefined value from the electronic level sensor. During first fill, this check is made to ensure that the mechanical level switch is activated when the water level exceeds the predefined value. If not, this error code is shown.

Predefined level value is defined in Config. 2 parameter `LEVEL DLCU.`

Possible causes:

- The mechanical level control can be damaged.
- Leakage or clogged level controls air hoses.

Recommended actions:

1. Check function of mechanical level switch by reading DLCU status in service mode.
2. Check the analog level control function by checking value in inputs.
3. Blow through the level hoses and check that they are not blocked and does not contain any water.
4. Check the cables and their connections.

### 11:29 WATER LEVEL LOW DLCU LEVEL HIGH

The DLCU on I/O type 10 contains a mechanical DLCU level switch which ensures that there is no water in the machine when the door unlocks opens. To ensure that the DLCU level switch functions correctly, the DLCU level switch status is compared with the value from the electronic level sensor. At program start and program end, when the water level is below `LEVEL EMPTY` value, a check is made to ensure that the mechanical level switch is not activated. If it is activated, this error code is shown.

The level empty value is defined in Config. 2 parameter `LEVEL EMPTY.`

Possible causes:

- The mechanical level control can be damaged.
- Mechanical level control is not connected or bad there is bad contact in the connector.
- Leakage or clogged level controls air hoses.
- Incorrect nominal value, possibly caused by a error in the electronic level control.

Recommended actions:

1. Check function of mechanical level switch by reading DLCU status in service mode.
2. Check the analog level control function by checking value in inputs.
3. Blow through the level hoses and check that they are not blocked and does not contain any water.
4. Check the cables and their connections.

### 11:126 CO2 BOTTLE EMPTY

This is only a warning message.

Shown when CO2 bottle is about to be empty and input `CO2 BOTTLE EMPTY` is activated.

Program will continue when message has disappeared.

**11:127 DRAWER OUT CLOSE TO START**

This is only a warning message.

Shown if input `DETERGENT BOX SENSOR` is active at program start or during program run if water is supposed to flush in detergent compartment.

The program will pause until input `DETERGENT BOX SENSOR` is deactivated.

The function to check for open detergent box can be turned off in Config 1 `DETERGENT BOX SENSOR`.



**PLATON SERVICE**

8 (800) 500-34-47

[www.platonservice.com](http://www.platonservice.com)



## MAIN DRYER

### 12:1 O.H. THERMOSTAT - INLET AIR

This error code is shown if the input O.H. INLET AIR is deactivated.

Normally this is due to that protection thermostat for inlet air has triggered due to overheating.

The overheating thermostat for inlet air needs to be mechanically restored.

Cut power and turn off gas supply (if gas heated) and check contactors/heat relays before restoring the thermostat.

When the overheating thermostat for inlet air has been restored and the machine is powered up again, the error code is cleared automatically.

The error code can be triggered if:

- The inlet air sensor has stopped operating correctly.
- The fan has stopped operating.
- The airflow is obstructed, by lint, overload, etc.
- The contactor or heat relay has got welded.

If the overheating thermostat for inlet air is not triggered, but there still is an error code:

- Check the harness, connectors and functions by reading the electrical schematic and by using the `SHOW INPUTS` menu when the machine is in service mode.

### 12:2 O.H. THERMOSTAT - OUTLET AIR

This error code is shown if the input O.H. OUTLET AIR is deactivated.

Normally this is due to that protection thermostat for outlet air has triggered due to overheating.

The overheating thermostat for outlet air needs to be mechanically restored.

Cut power and turn off gas supply (if gas heated) and check contactors/heat relays before restoring the thermostat.

When the overheating thermostat for outlet air has been restored and the machine is powered up again, the error code is cleared automatically.

The error code can be triggered if:

- The outlet air sensor has stopped operating correctly.
- The contactor or heat relay has got welded.

If the overheating thermostat for outlet air is not triggered, but there is still an error code:

- Check the harness, connectors and functions by reading the electrical schematic and by using the `SHOW INPUTS` menu when the machine is in service mode.

### 12:3 INLET AIR SENSOR - OPEN

The error code is shown if the analog input INLET AIR TEMP. (PT100) is reading a resistance of more than approximately 185  $\Omega$ . Probably caused by broken PT100 sensor or wiring.

If the inlet air temperature in the `SHOW INPUTS` menu show a temperature of 222 °C the inlet air sensor is considered open.

When the inlet air sensor is restored the error code is automatically reset and the ongoing program will continue.

A long press on the control knob/start button will make the control system reset and ongoing program will be ended.

The error code can be triggered if:

- The sensor, harness or connector is broken. The sensor shall measure around 110 Ohm in room temperature, see table. (Measure direct over the sensor connectors).

If the measure of inlet air sensor is OK, but there is still an error code:

- Check the harness, connectors and functions by reading the electrical schematic and by using the `SHOW INPUTS` menu when the machine is in service mode.

Temp - Sensor resistance

0°C / 32°F - 100  $\Omega$

20°C / 68°F - 107  $\Omega$

30°C / 86°F - 112  $\Omega$

200°C / 392°F - 176  $\Omega$



### 12:4 INLET AIR SENSOR - SHORT-CIRCUITED

The error code is shown if the analog input INLET AIR TEMP (PT100) is reading a resistance of less than 100  $\Omega$ . Probably caused by broken PT100 sensor or damaged wiring.

If the inlet air temperature in the `SHOW INPUTS` menu show a temperature of 0 °C the inlet air sensor is shorted.

When the inlet air sensor is restored the error code is automatically reset and the ongoing program will continue.

A long press on the control knob/start button will make the control system reset and ongoing program will be ended.

The error can be triggered if:

- The sensor, harness or connector is shorted. The sensor shall measure around 110 Ohm in room temperature, see table. (Measure direct over the sensor connectors).

If the measure of inlet air sensor is OK, but there is still an error code:

- Check the harness, connectors and functions by reading the electrical schematic and by using the `SHOW INPUTS` menu when the machine is in service mode.

Temp - Sensor resistance

0°C / 32°F - 100  $\Omega$

20°C / 68°F - 107  $\Omega$

30°C / 86°F - 112  $\Omega$

200°C / 392°F - 176  $\Omega$

### 12:5 OUTLET AIR SENSOR - OPEN

The error code is shown if the analog input OUTLET AIR TEMP (NTC) is reading a resistance of more than approximately 26.7 k $\Omega$ . Probably caused by broken NTC sensor or wiring.

If the outlet air temperature in the `SHOW INPUTS` menu shows a temperature of -10 °C the outlet air sensor is open.

When the outlet air sensor is restored the error code is automatically reset and the ongoing program will continue.

A long press on the control knob/start button will make the control system reset and ongoing program will be ended.

The error code can be triggered if:

- The sensor, harness or connector is broken. The sensor shall measure around 5 K Ohm in room temperature, see table. (Measure direct over the sensor).

If the measure of outlet air is OK, but there is still an error code:

- Check the harness, connectors and functions by reading the electrical schematic and by using the `SHOW INPUTS` menu when the machine is in service mode.

Temp - Sensor resistance

-10 °C - 26.7 k $\Omega$

15 °C - 7.6 k $\Omega$

20 °C - 6.0 k $\Omega$

25 °C - 4.8 k $\Omega$

30 °C - 3.9 k $\Omega$

100 °C - 0.33 k $\Omega$

### 12:6 OUTLET AIR SENSOR - SHORT-CIRCUITED

The error code is shown if the analog input OULET AIR TEMP (NTC) is reading a resistance of less than 330  $\Omega$ . Probably caused by broken NTC sensor or damaged wiring.

If the outlet air temperature in the `SHOW INPUTS` menu shows a temperature of 100 °C the outlet air sensor is shorted.

When the outlet air sensor is restored the error code is automatically reset and the ongoing program will continue.

A long press on the control knob/start button will make the control system reset and ongoing program will be ended.

The error code can be triggered if:

- The sensor, harness or connector is broken. The sensor shall measure around 5 K Ohm in room temperature, see table. (Measure direct over the sensor).

If the measure of outlet air sensor is OK, but there is still an error code:

- Check the harness, connectors and functions by reading the electrical schematic and by using the `SHOW INPUTS` menu when the machine is in service mode.

Temp - Sensor resistance

-10 °C - 26.7 k $\Omega$

15 °C - 7.6 k $\Omega$

20 °C - 6.0 k $\Omega$

25 °C - 4.8 k $\Omega$

30 °C - 3.9 k $\Omega$

100 °C - 0.33 k $\Omega$

### 12:8 CONDENSE WATER CONTAINER IS FULL

The pump will run when a program starts for normally 15 seconds. Then it will run again after normally 3 minutes.

The pump will also run if the input for the float is triggered.

The error code is activated if the input CONDENSER TANK is still activated after 15 seconds.

This means that the pump has tried to empty the condense water container without the signal from the float in the condense water container has been deactivated.

When the float in the condense water container is restored it is possible to reset the error code from the control system.

The error code is reset from the control system by a short press on the control knob/start button. A long press on the control knob/start button will make the control system reset and ongoing program will be ended.

The error code can be triggered if:

- The condense water container is full and the pump is not operating. Check the pump by activating the `CONDENSER PUMP` menu in the `ACTIVATE OUTPUTS` menu when the machine is in service mode.
- If the pump is running and no water is coming out, the drain is blocked or the float is out of order.
- If water coming out of the hose, it might be partly blocked.

If the pump does not run or if there is no level in the condense water container check the harness, connectors and functions by reading the electrical schematic and by using the `SHOW INPUTS` menu when the machine is in service mode.

### 12:9 HEAT PUMP LOW PRESSURE

The error code is shown if the input HP LOW PRESSURE (low pressure switch, P2) has tripped.

The error code can be triggered if there is too little refrigerant in the heat pump or by damaged wiring or connectors.

It can also be triggered if machine is started in a cold environment, or started with clogged lint filters.

The error can be restored with the knob when the pressure is restored and the ongoing program will continue.

Recommended actions:

1. Check the harness, connectors and functions by reading the electrical schematic and by using the `SHOW INPUTS` menu when the machine is in service mode.
2. Check airflow and clean filters.
3. Try to run again, if error still present, check the heat pump for gas leakage.

### 12:10 HP HIGH PRESSURE CHECK COOLING SYSTEM AND FILTERS

The error is activated if the input HP HIGH PRESSURE (high pressure switch, P1) has tripped.

The error can be triggered if there is no cooling water to machine or if the airflow is obstructed, by lint, overload, etc.

The error can be restored with the knob when the pressure is restored and the ongoing program will continue.

Recommended actions:

1. Check the harness, connectors and functions by reading the electrical schematic and by using the `SHOW INPUTS` menu when the machine is in service mode.
2. Check cooling water supply.
3. Check airflow and clean filters.

### 12:11 DRYING ERROR WITH RMC PROGRAM

The error code is shown if the analog input RMC does not register the STOP VALUE FOR RMC PROGRAM reached within the maximum drying time (normally 90 minutes). When the error is triggered the machine will automatically go to the cooling module before the program ends.

The program is ended and the error code is reset by opening the door.

If the clothes are still wet after maximum drying time and the dryer is not overloaded, check that the heating system is working correct by using the `ACTIVATE OUTPUTS` menu when the machine is in service mode.

#### Note!

**Make sure that the fan is active before turning on the heat.**

If the clothes are dry, check the RMC system and harness, connectors and functions by reading the electrical schematic and by using the `SHOW INPUTS` menu when the machine is in service mode.

- RMC value no load = 0%
- RMC value 100K Ohm between lifter and drum = ~24% (Putting your hand over the lifter onto the drum will result in approximately 20% RMC value)
- RMC value system short circuit = 50%

### 12:12 DRYING ERROR WITH AUTOSTOP PROGRAM

The error code is shown if the analog input OULET AIR TEMP (NTC) does not register the STOP VALUE FOR AUTOSTOP PROGRAM reached within the maximum drying time (normally 90 minutes).

When the error is triggered the machine will automatically go to the cooling module before the program ends.

The program is ended and the error code is reset by opening the door.

If the clothes are still wet after maximum drying time and the dryer is not overloaded, check that the heating system is working correct by using the `ACTIVATE OUTPUTS` menu when the machine is in service mode.

#### Note!

**Make sure that the fan is active before turning on the heat.**

If the clothes are dry, check the outlet air sensor and harness, connectors and functions by reading the electrical schematic and by using the `SHOW INPUTS` menu when the machine is in service mode.

### 12:13 DRYING ERROR WITH TIME PROGRAM

The error code is shown if a time program has continued longer than the maximum drying time (normally 90 minutes) without the door has been opened.

When the error is triggered the machine will automatically go to the cooling module before the program ends.

The program is ended and the error code is reset by opening the door.

### 12:14 GAS ERROR PRESS GAS RESET BUTTON

The error code is shown if input GAS ERROR is activated. This means that no flame has been detected by the gas control box.

The metal probe of the flame sensor generates an electrical current when exposed to the burner's flame. This signal is detected by the ignition control module which, in turn, cuts off the gas valve immediately if the sensor does not indicate flame within 3 attempts at each 10 seconds. The integrity of the sensor's electrical connection is, therefore, critical to proper operation of this system. When the gas control box is in error mode, a red LED is active on the gas control box. The gas control box also trigs input GAS ERROR on the control system , which generates the error code.

The control system sends a reset signal to the gas control box via output GAS ERROR RESET by a short press on the start button or service button (depending on market and segment). When the gas control box receive a reset command it removes the error. The control system will automatically restart the program when the error is removed from the gas control box and when heat is allowed (vacuum needed) the gas control box will try to ignite the gas again.

A long press on the control knob/start button will make the control system reset and ongoing program will be ended.

The gas error can also be reset at the gas control box. The machine will automatically restart when the error is restored.

The error code can be triggered if:

- The gas control box fails to ignite. Check the gas supply and nozzle pressure.

If the gas control box do not have a gas error but the control system does, check the harness, connectors and functions by reading the electrical schematic and by using the SHOW INPUTS menu when the machine is in service mode.

### 12:15 NO VACUUM

The error code is shown if the input VACUUM is not activated within set time in parameter TIMEOUT VACUUM.

The error code is reset from the control system by a short press on the control knob/start button. A long press on the control knob/start button will make the control system reset and ongoing program will be ended.

The time is defined in Config. 1 parameter TIMEOUT VACUUM.

The error code can be triggered if:

- The fan is not operating or blows in the wrong direction.
- The airflow is obstructed.
- The vacuum switch sensor or hose is disconnected.
- The lint drawer is open, etc.

Check the harness, connectors and functions by reading the electrical schematic and by using the SHOW INPUTS and ACTIVATE OUTPUTS menus when the machine is in service mode.

### 12:16 VACUUM SWITCH SHORTED

The error code is shown if the input VACUUM was already activated when a program was started.

The error code is reset from the control system by a short press on the control knob/start button. A long press on the control knob/start button will make the control system reset and ongoing program will be ended.

Recommended actions:

1. Check the vacuum switch/pressure sensor, harness, connectors and functions by reading the electrical schematic and by using the SHOW INPUTS menu when the machine is in service mode.

### 12:17 AIRFLOW OBSTRUCTED MAINTENANCE NEEDED

The error is shown if input INTERNAL FILTER is activated.

Error can be triggered by clogged internal filter, damaged vacuum switch or harness.

Recommended actions:

1. Check and clean internal filters, see maintenance manual.
2. Check the harness, connectors and functions by reading the electrical schematic and by using the SHOW INPUTS menu when the machine is in service mode.
3. If permanent clean heat pump box.

### 12:18 REDISTRIBUTION OF LOAD NEEDED

The error code is shown if the input VACUUM has deactive several times during program run and the function to handle vacuum error during program run has failed to recreate vacuum in the machine. The error code is reset from the control system by a short press on the control knob/start button. A long press on the control knob/start button will make the control system reset and ongoing program will be ended.

The error code can be triggered if:

- The load is blocking the airflow.

Check the load and redistribute it in the drum.

### 12:253 JUMPER 1

The error code is shown if input JUMPER 1 is not activated.

Jumpers are a by-pass of inputs not used in the machine. How many jumpers used is depending on configuration.

When the jumper is restored the error code is automatically reset and the ongoing program will continue. A long press on the control knob/start button will make the control system reset and ongoing program will be ended.

Recommended actions:

Check the harness, connectors and functions by reading the electrical schematic and by using the `SHOW INPUTS` menu when the machine is in service mode.

### 12:254 JUMPER 2

The error code is shown if input JUMPER 2 is not activated.

Jumpers are a by-pass of input not used in the machine. How many jumpers used is depending on configuration.

When the jumper is restored the error code is automatically reset and the ongoing program will continue. A long press on the control knob/start button will make the control system reset and ongoing program will be ended.

Recommended actions:

1. Check the harness, connectors and functions by reading the electrical schematic and by using the `SHOW INPUTS` menu when the machine is in service mode.

### 12:255 JUMPER 3

The error code is shown if input JUMPER 3 is not activated.

Jumpers are a by-pass of input not used in the machine. How many jumpers used is depending on configuration.

When the jumper is restored the error code is automatically reset and the ongoing program will continue. A long press on the control knob/start button will make the control system reset and ongoing program will be ended.

Recommended actions:

1. Check the harness, connectors and functions by reading the electrical schematic and by using the `SHOW INPUTS` menu when the machine is in service mode.

## MAIN BARRIER

### 13:1 DRUM POSITIONING TIMED OUT

The error code is shown if input POSITION DRUM 1 and POSITION DRUM 2 is not activated within set time in Config parameter DRUM POS TIMEOUT.

Recommended actions:

1. Check inputs from positioning sensors DP1 and DP2.

### 13:2 DRUM LOCKING / UNLOCKING

The error code is shown if drum is not able to unlock/lock when expected.

This is detected by the input sensors DRUM UNLOCKED (FC1) and DRUM LOCKED (FC2).

Recommended actions:

1. Check functionality of drum lock position sensors FC1 and FC2.
2. Check functionality of drum locking piston, i.e that it operates normal and could activate/inactivate. This could be done by running a positioning sequence in service program or by running a program.

### 13:3 INNER DOOR OPENING

Machine indicates that the automatic inner door JACK (Piston) has not left the home position within a reasonable time.

The error code is shown if the sensor for JACK AT HOME (backwards position) is still active when JACK is expected to be in forward position.

Recommended actions:

1. Check functionality JACK\_AT\_HOME sensor DP8, i.e active when jack is in backward position, inactive when JACK is in forward position.
2. Check functionality for JACK, i.e that it could move forward when expected.

### 13:4 INNER DOOR JACK POSITION

Machine indicates that the inner door opening jack is not in home position when the drum is rotating.

The error code is shown if input JACK AT HOME is not active when the reported motor speed is not zero.

Recommended actions:

1. Check functionality for JACK, i.e that it is in backwards position when expected.
2. Check functionality JACK\_AT\_HOME sensor DP8, i.e active when jack is in backward position, inactive when JACK is in forward position.
3. Check wiring to JACK\_AT\_HOME sensor DP8, bad contact in the sensor could cause this problem.

### 13:5 DOOR UNLOCKING

Machine indicates that either loading or unloading door is not able to unlock.

The error code is shown if inputs LOADING DOOR LOCKED or UNLOADING DOOR LOCKED does not get inactive within a reasonable time after door unlock command is sent.

Recommended actions:

1. Check door lock functionality in service program, by activating door lock and then by monitoring input and output status under Check inputs and outputs.
2. Check electrical connections by reading inputs at the same time as cables carefully moved/pulled.



### 13:6 DRUM LOCK POSITION SWITCH

The error code is shown if inputs DRUM UNLOCKED and DRUM LOCKED are both active or inactive at the same time during program run. Since it occurs during program run it is required to turn power off to the machine to clear the error message.

Possible causes:

Heavy unbalance in drum that prevents the motor to position the drum. Worst case scenario is wet load in one compartment.

Could also depend on problems with indexing sensors, washer I/O board or malfunction in mechanical drum lock function.

Recommended actions:

1. Check inputs from indexing sensors FC1 and FC2.
2. Run a positioning sequence with wet load in one compartment to test functionality.

### 13:7 DRUM NOT ROTATING

The error code is shown if positioning sensor on input on J201 is not indicating rotation when rotation is expected during program run.

Recommended actions:

1. Check that drive belt is not broken.
2. Check positioning sensor on input J201.

### 13:8 UNBALANCE SWITCH ON AT PROG START

The error code is shown if unbalance switch is active at program start.

Recommended actions:

1. Check unbalance switch for proper alignment.
2. Check unbalance switch for electrical fault.

### 13:9 WATER IN DRUM - CALL SERVICE

This error code will be shown if the control system detects water above safety level when program is finished.

Possibly caused by broken inlet valve and / or drain valve.

Recommended actions:

1. Turn off water inlet to machine.
2. Manually open the drain valve.
3. Check reason for valve malfunction.

### 13:10 WATER IN DRUM - CALL SERVICE

This error code will be shown if the control system detects water above safety level in idle mode. Possibly caused by broken inlet valve and / or drain valve.

Recommended actions:

1. Turn off water inlet to machine.
2. Manually open the drain valve.
3. Check reason for valve malfunction.

**13:11 UNLOADING DOOR NOT LOCKED**

This error code will be shown if the control system has not detected the input UNLOADING DOOR LOCKED to be active within a certain time after closing the unloading door.

Possible causes:

This can be caused by a mechanical problem preventing door lock to lock, defective door lock, loose cable connection to door lock, broken cables to door lock or mechanical problem with emergency opening of the door.

Recommended actions:

1. Check door lock functionality in service program, by activating door lock and then by monitoring input status under Check inputs and outputs.
2. Check electrical connections by reading inputs at the same time as cables carefully moved/pulled.
3. Carefully knock on the door lock unit to locate intermittent errors.

**13:12 LOADING DOOR NOT LOCKED**

This error code will be shown if the control system detects that the input LOADING DOOR LOCKED has been deactivated during an on-going program.

Possible causes:

This can be caused by a mechanical problem preventing door lock to lock, defective door lock, loose cable connection to door lock, broken cables to door lock or mechanical problem with emergency opening of the door.

Recommended actions:

1. Check door lock functionality in service program, by activating door lock and then by monitoring input status under Check inputs and outputs.
2. Check electrical connections by reading inputs at the same time as cables carefully moved/pulled.
3. Carefully knock on the door lock unit to locate intermittent errors.

**13:13 UNLOADING DOOR NOT LOCKED**

This error code will be shown if the control system detects that the input UNLOADING DOOR LOCKED has been deactivated during an on-going program.

Possible causes:

This can be caused by a mechanical problem preventing door lock to lock, defective door lock, loose cable connection to door lock, broken cables to door lock or mechanical problem with emergency opening of the door.

Recommended actions:

1. Check door lock functionality in service program, by activating door lock and then by monitoring input status under Check inputs and outputs.
2. Check electrical connections by reading inputs at the same time as cables carefully moved/pulled.
3. Carefully knock on the door lock unit to locate intermittent errors.

**13:14 INNER DRUM DOOR NOT CLOSED**

This error code will be shown if the control system detects that the input INNER DOOR OPEN is activated during program start or becomes activate when drum is ordered to drive/drum is rotating.

Recommended actions:

1. Check functionality of INNER DOOR OPEN SENSOR (DP7), i.e inactive when door is closed and active when door is open.
2. Check door lock functionality in service program, by activating door lock and then by monitoring input status under Check inputs and outputs.

**13:15 COMPRESSED AIR IS MISSING**

Machine indicates that compressed air is missing.

This error code will be shown if the control system detects that the input COMPRESSED AIR PRESENT is not activated.

Recommended actions:

1. Check compressed air pressure to machine, valves is open, compressor on etc.
2. Check that input COMPRESSED AIR PRESENT activates when compressed air is present.



### 13:16 DRUM LOCK POSITION SWITCH

The error code is shown if inputs DRUM UNLOCKED and DRUM LOCKED are both active or inactive at the same time during positioning sequence. By pressing the start button it is possible to have another trial.

Possible causes:

Heavy unbalance in drum that prevents the motor to position the drum. Worst case scenario is wet load in one compartment. Could also depend on problems with indexing sensors, washer I/O board or malfunction in mechanical drum lock function.

Recommended actions:

1. Check inputs from indexing sensors FC1 and FC2.
2. Run a positioning sequence with wet load in one compartment to test functionality.

## MAIN W&D

### 14:1 EXTRACTION FAILED DRYING ABORTED

Only on Wash & Dryer. If extraction is omitted, the drying sequence will also be omitted.



PLATON SERVICE

8 (800) 500-34-41

www.platonservice.com

## MAIN DRYER

### 15:2 UNLOADING DOOR OPEN

Only on Pocket washer:

This error code will be shown if the control system detects that the input DOOR CLOSED 2 (unloading side) has been deactivated during an on-going program.

The error can only occur during an on-going program.

Possible causes:

This can be caused by for example a bad or defective door lock, loose cable to door lock, problem with door lock edge connection, defective input on I/O unit type 10 etc.

Recommended action:

1. Check door lock functionality in service program, but activating door lock and then by checking inputs.
2. Check electrical connections by reading inputs at the same time as cables carefully moved/pulled.
3. Carefully knock on the door lock to locate intermittent errors.

### 15:3 UNLOADING DOOR NOT LOCKED

Only on Pocket washer:

This error code will be shown if the control system detects that the input DOOR LOCKED 2 has not been activated within a certain time after unloading door is closed.

It will also be activated if the input DOOR LOCKED 2 has been deactivated during an on-going program.

Possible causes:

This can be caused by a mechanical problem preventing door lock to lock, defective door lock, loose cable connection to door lock, broken cables to door lock or mechanical problem with emergency opening of the door.

Recommended actions:

1. Check door lock functionality in service program, but activating door lock and then by checking check inputs.
2. Check electrical connections by reading inputs at the same time as cables carefully moved/pulled.
3. Carefully knock on the door lock unit to locate intermittent errors.
4. Check DLCU 2 status in service mode for more information on possible causes.

### 15:17 DOOR LOCK

Only on Pocket washer running with one door setup.

This error code is activated if the input for DOOR LOCKED 2 is active at program start, i.e. the door is locked although the control system has not requested locking.

Possible causes:

- DLCU 2 is in error mode after previous program run.
- Door lock solenoid broken.

Recommended actions:

1. Check door lock functionality in service program, by activating door lock and then by checking check inputs.
2. Check DLCU 2 status in service mode for more information on possible causes.
3. If DLCU 2 is in error mode, wait five minutes for automatic reset or manually reset the DLCU 2 in service mode.

## DRUM MOTOR COMMON

### 20:1 O.H. DRUM MOTOR

This error code will be shown if the control system detects that the input OH DRUM MOTOR is deactivated during program run.

The overheating protection is automatically restored. When the overheating protection is restored the error code is automatically reset and the ongoing program will continue. A long press on the control knob/start button will make the control system reset and ongoing program will be ended.

The error code can be triggered if:

1. The motor is very warm. Check that the vent holes in the motor are not covered.  
If the overheating protection is not triggered, but there is still an error code:
2. Check the harness, connectors and functions by reading the electrical schematic and by using the `SHOW INPUTS` menu when the machine is in service mode.

### 20:2 NO MOTOR COMMUNICATION

This error code occurs if the first message sent from the CPU to the MCU was not replied to during start up.

Recommended actions:

1. Check that there is power reaching the MCU. Check the fuses in the Protection Cable. If one of the components in the Protection Cable is damaged, the cable must be replaced.
2. Check that the green power indication LED on the MCU is on. The LED can be seen by looking down by the MCU edge connections.
3. Check that the communication cable between the CPU board and the MCU is intact and not damaged. Measure also with a reference instrument to see whether there is contact between all the leads in the communication cable.

### 20:3 LOST MOTOR COMMUNICATION

This error code occurs if the communication between the CPU and the MCU has stopped working.

Recommended actions:

1. Check that there is power reaching the MCU. Check the fuses in the Protection Cable. If one of the components in the Protection Cable is damaged, the cable must be replaced.
2. Check that the indicator LED on the MCU is on. The LED can be seen by looking down by the MCU edge connections.
3. Check that the communication cable between the CPU board and the MCU is intact and not damaged. Measure also with a reference instrument to see whether there is contact between all the leads in the communication cable.

## DRUM MOTOR EWD

### 21:1 HEATSINK TOO HOT

This error code is generated by the MCU for drum motor.

There is a temperature sensor (NTC) mounted on the MCU cooling flange next to the power transistors in the output stage. If the temperature of the cooling flange gets too high ( $> 90^{\circ}\text{C}$ ) the error code will be set to protect the transistors.

The cause of high cooling flange temperature can be e.g. a stiff drum in combination with intensive use and high ambient temperature. There may also be an error in the motor (sticking bearings or short circuit in windings, which impairs the efficiency of the motor).

Recommended actions:

1. Make sure the drum turns easily.
2. Check the value on the error code counter for the error code.
3. Check the last 8 MCU error codes.
4. Start a  $90^{\circ}\text{C}$  normal program with load on continuous operation and measure the temperature of the motor and MCU.
5. Replace the defective part.

### 21:2 MOTOR TOO HOT

This error code is generated by the MCU for the drum motor.

Each time the motor is started from stationary, the MCU will first measure the resistance between two phases in the motor. The MCU processor governs the output transistors so that a DC current flows between two phases in the motor winding. The actuation of the transistors is a measure of the voltage applied to the winding and the resistance can be calculated using the current and voltage values. The resistance can then be converted to a temperature since the winding resistance at  $20^{\circ}\text{C}$  and the temperature coefficient are known. If the average value of the four latest temperature readings is higher than the maximum motor temperature (e.g.  $150^{\circ}\text{C}$ ), the error code will be shown.

Possible causes:

The cause of high motor temperature can be a stiff drum, possibly in combination with intensive use and high ambient temperature. There may also be an error in the motor (sticking bearings or short circuit in windings, which impairs the efficiency of the motor). There could also be a contact error in the connectors between the MCU and the motor or an error in the motor cable. An error in MCU temperature measurement circuits can also occur.

Recommended actions:

- Make sure the drum turns easily.
- Check the value on the error code counter for the error code.
- Check the last 8 MCU error codes.
- Measure the three phases to the phase resistors on the MCU motor connector (disconnect MCU and take the reading in the cable connector) to make sure they are the same.
- Start a  $90^{\circ}\text{C}$  normal program with load on continuous operation and measure the temperature of the motor and MCU.
- Replace the defective part.

### 21:3 NO INTERLOCK

This error code is generated by the MCU for drum motor.

The MCU must be powered with 230V / 50 or 60 Hz on the interlock input in order to drive the motor. This signal is a confirmation that the door is closed and locked.

MCU receives its commands to rotate the drum from the CPU via a serial communication link between the MCU and CPU. Since the CPU also has access to the interlock signal, the CPU must never send a run command to the MCU if the interlock signal is missing. If this does happen, this error code will be shown.

Possible causes:

The cause of this error code being activated can be e.g. a break in the cable leading the interlock signal to the MCU. There may also be an error in the connector in the door lock, which connects 230V / 50 Hz to the interlock signal. An error in the interlock circuits of the MCU can also set this error code.

Recommended actions:

1. Use a multimeter to check that the interlock signal is present on X302:1-2 when the door lock is activated. Read also bit 1 in the second byte under `MCU STATUS` in the service program (the bits are numbered from 0 to 7 where bit 0 is on the far right). If bit 1 in the second byte is 1 then the lock is open, while a 0 indicates that the lock is closed.
2. Replace the defective part.

### 21:4 NO COMMUNICATION

This error code is generated by the MCU for drum motor.

MCU detects there is there is a problem in communication with CPU.

Possible causes:

Bad contact in harness or connectors between CPU and MCU.

Recommended actions:

1. Check wiring, connections between CPU and MCU.

### 21:5 MOTOR SHORT CIRCUIT

This error code is generated by the MCU for drum motor.

The MCU reads the power consumption of the motor continuously. If the current for some reason exceeds a predetermined limit, the MCU will cut the current to the motor. After the motor has stopped (= tachometer indicates stationary motor), the MCU will attempt to restart it. If the MCU then detects high motor current again, this error code will be activated. If on restarting after a first short circuit, the MCU rotates normally, the error code will not be shown.

Possible causes:

This error code can be activated for a number of reasons:

- Short circuit in motor. Measure motor windings with a Motor Tester.
- Short circuit internally in motor winding (impaired efficiency, higher current consumption).
- Short circuit in motor cables.
- Short circuit in connectors.
- Drops of water causing short circuits in the motor connector.
- Short circuit in the MCU output transistors.
- Bad contact in tacho signal.
- Bad contact in interlock signal.

Recommended actions:

1. If the error is a stable one, it is generally not difficult to locate the defective unit through resistance measurement and testing with the service program. Measure motor windings with a Motor Tester.
2. Further information can be obtained by studying the contents of `MCU ERROR LOG 1` and `MCU ERROR LOG 2`. Review following:

`SHORT CIRCUIT 2` (specifies how many times the error code has been active).

`SHORT CIRCUIT 1` (specifies how many times the current limit has been exceeded. The difference between short circuit 1 and short circuit 2 indicates how many times there has been a short circuit 1 that has not been confirmed when restarting the motor).

`LAST FAULT CODE N/8` (shows the 8 latest error codes).

`TACHO ERR. LOW SPEED` (can give a clue in case of intermittent errors).

`TACHO ERR. HIGH SPEED` (can give a clue in case of intermittent errors).

### 21:6 INTERLOCK HARDWARE

This error code is generated by the MCU for drum motor.

The MCU must be powered with 230V / 50 or 60 Hz on the interlock input in order to drive the motor. The interlock circuits in the MCU have been split into two channels so that a component error in MCU cannot give a false confirmation that the door is locked. These two channels are checked against each other. If this check gives an incorrect result this error code will be shown.

Possible cause:

The reason for this error code being activated can be attributed to an error in the interlock circuits in motor control.

Recommended actions:

1. Replace MCU.

### 21:7 LOW DC VOLTAGE

This error code is generated by the MCU for drum motor.

The MCU constantly measures the voltage over the mains input. If the voltage is below a predefined limit, the MCU will shut off the current to the motor. Once the motor has stopped (= the tach sensor indicates that the motor is stationary), the MCU checks to see whether the input voltage is still low. If it is, this error code is shown. The reason for this error code being activated can be low mains voltage or that the machine's on/off switch has been operated in an unsuitable manner.

Further information can be obtained by studying the contents of MCU ERROR LOG 1 and MCU ERROR LOG 2:

- UNDERVOLTAGE 2 (specifies how many times this error code has been active).
- UNDERVOLTAGE 1 (specifies how many times the voltage has dropped below the limit. The difference between undervoltage 1 and undervoltage 2 indicates how many times there has been an undervoltage 1 without it being confirmed when the motor has stopped).
- LAST FAULT CODE N/8 (shows the 8 latest error codes) Undervoltages can be registered even during normal operation. Consequently, a small number of registrations need not mean that there is an error in the MCU.

Recommended actions:

1. Check that the supply voltage is stable and never drops below nominal voltage - 10%.
2. Check the fuses and cables.
3. Check the supply voltage in the network cabling and at the MCU in the machine.

### 21:8 HIGH DC VOLTAGE

This error code is generated by the MCU for drum motor.

The MCU constantly measures the voltage over the mains input. If the voltage exceeds a predefined limit, the MCU will shut off the current to the motor. Once the motor has stopped (= the tach sensor indicates that the motor is stationary), the MCU checks to see whether the input voltage is still high. If it is, this error code is shown.

Recommended actions:

1. Check incoming AC voltage.

### 21:12 NO PARAMET. SET IN MCU

This error code is generated by the MCU for drum motor.

The MCU contains several different parameter sets for different motors. During power up the control system checks that the correct parameter set digit is written into the MCU. If not, the control system will write down the parameter set digit defined in fixed configuration.

If the MCU discovers that no parameter set value is written down into the MCU, the error code will be shown.

Possible causes:

This can be caused by wrong software in CPU or wrong MCU for the current machine.

Recommended actions:

1. Make sure correct machine software and correct MCU are used.

### 21:13 UNBALANCE

This error code is generated by the MCU for drum motor.

The MCU monitors the unbalance switch status. If the status is active already at program start, this error code is shown.

### 21:15 MOTOR NOT FOLLOW

This error code is generated by the MCU. The MCU must always receive information on the rotation of the motor from the tacho sensor in order to rotate. If the tacho sensor is not working, the motor can rotate for max. 10 seconds during the starting process. After this period, this error code will be activated.

Possible causes:

- Break in the cables between the tacho sensor and the MCU.
- Break in connectors in tacho cables.
- Break in one of the phases to the motor (cables or connectors). This error can be suspected if the motor does not rotate for 10 seconds (the motor will not start with only two phases).
- Error in tacho generator.
- Error in tacho circuits in the MCU.

Further information can be obtained by studying the contents of MCU ERROR LOG 1 and MCU ERROR LOG 2. Study the following:

- MOTOR NOT FOLLOW (specifies how many times this error code has occurred).
- LAST ERROR CODE N/8 (shows the 8 latest error codes).
- TACHO ERR. LOW SPEED (can give a clue in case of intermittent errors).
- TACHO ERR. HIGH SPEED (can give a clue in case of intermittent errors).

Recommended actions:

1. Replace the defective part.

### 21:255 UNDEFINED ERROR

This error code is generated by the MCU. The MCU reports an error that is not defined.



PLATON SERVICE  
8 (800) 500-34-41  
www.platonservice.com



## DRUM MOTOR KEB

### 22:0 SECURITY INPUT

Machine indicates that Interlock signal is missing to MCU.

Internal MCU error code STO.

The interlock signal is missing to MCU STO1+ or STO2+ inputs when expected to be active.

Recommended actions:

1. Verify STO 1+ signal from Loading Door or Unloading door locked sensors.
2. Verify STO 2+ signal from Emergency switch on loading or unloading side.

### 22:1 OVERVOLTAGE

The Motor Control Unit indicates error E.OP.

Voltage in DC-link too high.

Internal message 1.

Recommended actions:

1. Verify input voltage supply to machine (all phases).
2. Check that input choke is connected.
3. Check if braking resistor is defective.
4. Switch off the mainpower for 2 minutes.
5. Restart the machine.

### 22:2 UNDERVOLTAGE

The Motor Control Unit indicates error E.UP.

Voltage in DC-link too low.

Internal message 2.

Recommended actions:

1. Verify input voltage supply to machine (all phases).
2. Switch off the mainpower for 2 minutes.
3. Restart the machine.

### 22:3 PHASE FAILURE

The Motor Control Unit indicates error E.UPh.

One phase of input voltage missing. (Ripple detected).

Internal message 3.

Recommended actions:

1. Check power supply.
2. Check for blown fuses.

### 22:4 OVERCURRENT

The Motor Control Unit indicates error E.OC.

Peak current too high.

Internal message 4.

Recommended actions:

1. Verify that the load in the machine does not exceed maximum load.
2. Verify that the load in the machine have distributed correctly before spin.
3. Check FC for short-circuit at output transistors.
4. Check motor including cable for short-circuit.
5. Switch off the main power to machine for 5 minutes.
6. Restart the machine.



### 22:6 OVERHEAT INTERNAL

The Motor Control Unit indicates error E.OHI.

Internal overheating in frequency controller. Can only be reset when internal temperature has dropped by 3 °C.

This is indicated by message E.nOHI. See also error code 22:7.

Internal message 6.

Recommended actions:

1. Switch off the main power to machine for 30 minutes.
2. Restart the machine.

### 22:7 NO OVERHEAT INTERNAL

The Motor Control Unit indicates error E.nOHI.

Error `OVERHEAT INTERNAL` is reset. See also error code 22:6.

Internal message 7.

Recommended actions:

1. Switch off the main power to machine for 5 minutes.
2. Restart the machine.

### 22:8 OVERHEAT POWER MODULE

The Motor Control Unit indicates error E.OH.

Too high temperature on power module heat sink.

Error can only be reset when temperature is normal again. This is indicated by message E.nOH. See also error code 22:36.

Internal message 8.

Recommended actions:

1. Check that cooling fan is working and that fan grid is not clogged..
2. Check that heat sink is not soiled.
3. Very high ambient temperature.
4. Switch off the main power to machine for 30 minutes.
5. Restart the machine.

### 22:9 DRIVE OVERHEAT

The Motor Control Unit indicates error E.dOH.

Motor temperature too high. Can only be reset when motor temperature has dropped (E.ndOH, Resistance at terminals T1/T2 > 1650 Ω) This is indicated by message E.ndOH. See also error code 22:11)

Internal message 9.

Recommended actions:

1. Switch off the mainpower for 30 minutes until motor has cooled down.
2. Restart the machine. If problem persists, check motor windings etc.

### 22:11 NO DRIVE OVERHEAT

The Motor Control Unit indicates error E.ndOH.

Error `MOTOR OVERHEAT` is reset. See also error code 22:9.

Internal message 11.

Recommended actions:

1. Switch off the main power to machine for 5 minutes.
2. Restart the machine.

**22:12 POWER UNIT**

The Motor Control Unit indicates error E.Pu.

General power circuit fault.

Internal message 12.

Recommended actions:

1. Switch off the main power to machine for 5 minutes.
2. Restart the machine.

**22:13 POWER UNIT NOT READY**

The Motor Control Unit indicates message nO\_PU.

Power circuit not ready or identified by controller.

Internal message 13.

Recommended actions:

1. Wait 2 minutes and try to start again.
2. Switch off the main power to machine for 5 minutes.
3. Restart the machine.

**22:14 POWER UNIT INVALID**

The Motor Control Unit indicates error E.PUIN.

Power unit invalid. Software version in power module and control board does not match.

Internal message 14.

**22:15 LOAD SHUNT FAULT**

The Motor Control Unit indicates error E.LSF.

Load-shunt relay is not ready. Appears for a short time during switch-on.

Internal message 15.

If message remains, check following:

1. Wrong input voltage or too low.
2. Braking resistor defective or wrongly connected.
3. Hardware fault in controller.
4. Switch off the main power to machine for 5 minutes.
5. Restart the machine.

**22:16 OVERLOAD**

The Motor Control Unit indicates error E.OL.

Overload counter has reached 100%.

The error can only be reset after overload counter has reached 0% again. This is indicated by the message E.nOL.  
See also error 22:17.

Internal message 16.

Leave machine powered up without running any program for 30 minutes.

1. Check machine is not loaded more than intended.
2. Check motor and drum for mechanical fault. (jamming).
3. Check motor for electrical fault.
4. Switch off the main power to machine for 5 minutes.
5. Restart the machine.

**22:17 NO OVERLOAD**

The Motor Control Unit indicates error E.nOL.

Overload counter is reset to 0%. See also error 22:16.

Internal message 17.

1. Switch off the main power to machine for 5 minutes.
2. Restart the machine.

**22:18 BUS**

The Motor Control Unit indicates error E.buS.

Timeout of monitoring time of communication between operator unit and inverter (Watchdog).

Internal message 18.

1. Switch off the main power to machine for 5 minutes.
2. Restart the machine.

**22:19 OVERLOAD 2**

The Motor Control Unit indicates error E.OL2.

Standstill constant current exceeded.

The error can only be reset after cooling time has elapsed. This is indicated by the message E.nOL2. See also error code 22:20.

Internal message 19.

1. Wait until message 22:20, No ERROR over load 2 is shown.
2. Switch off the main power to machine for 5 minutes.
3. Restart the machine.

**22:20 NO OVERLOAD 2**

The Motor Control Unit indicates error E.nOL2.

Cooling time has elapsed, error over load 2 is reset. See also error code 22:19

Internal message 20.

1. Restart the machine.

**22:21 EEPROM DEFECTIVE**

The Motor Control Unit indicates error E.EEP.

EEPROM defective.

Internal message 21.

1. Switch off the main power to machine for 5 minutes.
2. Restart the machine.

**Note!**

**The EEPROM can not be written to, meaning parameter changes are not possible.**

**22:22 POWER UNIT COMMUNICATION**

The Motor Control Unit indicates error E.PUCO.

Parameter value could not be written to power circuit.

Internal message 22.

1. Switch off the main power to machine for 5 minutes.
2. Restart the machine.

**22:23 BUS SYNCHRON.**

The Motor Control Unit indicates error E.SbuS.  
Problem with Bus synchronization.  
Internal message 23.

1. Switch off the main power to machine for 5 minutes.
2. Restart the machine.

**22:30 MOTOR PROTECTION**

The Motor Control Unit indicates error E.OH2.  
Electronic motor protection relay has tripped.  
Internal message 30.

1. Switch off the main power to machine for 5 minutes.
2. Restart the machine.

**22:31 EXTERNAL FAULT**

The Motor Control Unit indicates error E.EF.  
External fault. This error can be triggered if a digital input is programmed as external error input, and trips. Not used in this application.  
Internal message 31.

**22:32 ENCODER 1**

The Motor Control Unit indicates error E.EnC.  
Cable breakage in the encoder. Not used in this application.  
Internal message 32.

**22:33 POWER FACTOR CONTROL**

The Motor Control Unit indicates error E.PFC.  
Error in the power factor control.  
Internal message 33.

1. Switch off the main power to machine for 5 minutes.
2. Restart the machine.

**22:36 NO OVERHEAT POWER MODULE**

The Motor Control Unit indicates error E.nOH.  
Temperature on heat sink is within permissible range again. See also error 22:8.  
Internal message 36.

1. Restart the machine.

**22:39 SET**

The Motor Control Unit indicates error E.SET.  
It has been attempted to access a locked parameter set.  
Internal message 39.

Recommended actions:

1. Upgrade machine software to latest version. Restart machine.

**22:46 PROTECT. ROT. FORWARD**

The Motor Control Unit indicates error E.PrF.  
Forward (right) limit switch is activated. Not used in this application.  
Internal message 46.

**22:47 PROTECT. ROT. REVERSE**

The Motor Control Unit indicates error E.Prr.

Reverse (left) limit switch is activated. Not used in this application.

Internal message 47.

**22:49 POWER UNIT CODE INVALID**

The Motor Control Unit indicates error E.Puci.

Power unit code invalid. During initialization the power unit was not recognized or identified as invalid.

Internal message 49.

Recommended actions:

1. Switch off the main power to machine for 5 minutes.
2. Restart the machine.

**22:50 POWER UNIT CHANGED**

The Motor Control Unit indicates error E.Puch. Power unit changed.

Power module ID was changed. With a valid power unit the error can be reset by writing to SY.3, see inverter manual.

Mismatch between CPU module and Power module internally in Frequency controlled due to bad contact.

Internal message 50.

Recommended actions:

1. Switch off the main power to machine for 5 minutes.
2. Restart the machine.

**22:51 DRIVER RELAY**

The Motor Control Unit indicates error E.dri.

Error in Driver relay.

Internal message 51.

Recommended actions:

1. Switch off the main power to machine for 5 minutes.
2. Restart the machine.

**22:52 HYBRID**

The Motor Control Unit indicates error E.Hyb.

Error hybrid. Invalid encoder interface identifier. Not used in this application.

Internal message 52.

**22:54 COUNTER OVERRUN 1**

The Motor Control Unit indicates error E.co1.

Counter overflow encoder channel 1. Not used in this application

Internal message 54.

**22:55 COUNTER OVERRUN 2**

The Motor Control Unit indicates error E.co2.

Counter overflow encoder channel 2. Not used in this application

Internal message 55.

**22:56 BRAKE**

The Motor Control Unit indicates error E.br.

Error brake. Not used in this application.

Internal message 56.

**22:57 INITIALISATION MFC**

The Motor Control Unit indicates error E.Inl.  
MFC not booted.  
Internal message 57.

**22:58 OVER SPEED**

ERROR over speed in KEB Motor Control Unit.  
Internal message 105.  
Recommended actions:

1. Restart the machine.

**22:87 OVERHEAT INT.**

Warning: The Motor Control Unit indicates A.OHI.  
Internal overheating in frequency controller. Can only be reset when internal temperature has dropped by 3 °C.  
This is indicated by message A.nOHI. See also error code 22:92.  
Internal message 87.

Recommended actions:

1. Switch off the main power to machine for 30 minutes.
2. Restart the machine.

**22:88 NO OVERHEAT POWER MODULE**

Warning: The Motor Control Unit indicates A.nOH.  
Warning Overtemperature of power module heat sink is reset. See also error code 22:89.  
Internal message 88.

Recommended actions:

1. Restart the machine.

**22:89 OVERHEAT POWER MODULE**

Warning: The Motor Control Unit indicates A.OH.  
Overtemperature of power module heatsink. See also error code 22:88.  
Internal message 89.

Recommended actions:

1. Switch off the main power to machine for 30 minutes.
2. Restart the machine.

**22:90 EXTERNAL FAULT**

Warning: The Motor Control Unit indicates A.EF.  
External fault. This warning can be triggered if a digital input is programmed as external error input, and trips. Not used in this application.  
Internal message 90.

**22:91 NO DRIVE OVERHEAT**

Warning: The Motor Control Unit indicates A.ndOH.  
Warning Drive motor overheat is reset. See also error code 22:96.  
Internal message 91.

Recommended actions:

1. Restart the machine.

**22:92 NO OVERHEAT INT.**

Warning: The Motor Control Unit indicates A.nOHI.

Overheat internal is reset. See also error code 22:87.

Internal message 92.

Recommended actions:

1. Restart the machine.

**22:93 BUS**

Warning: The Motor Control Unit indicates A.buS.

Timeout of monitoring time of communication between bus operator and inverter (Watchdog).

Internal message 93.

Recommended actions:

1. Switch off the main power to machine for 5 minutes.
2. Restart the machine.

**22:94 PROTECT. ROT. FORWARD**

The Motor Control Unit indicates error A.PrF.

Forward (right) limit switch is activated. Not used in this application.

Internal message 94.

**22:95 PROTECT. ROT. REVERSE**

The Motor Control Unit indicates error A.Prr.

Reverse (left) limit switch is activated. Not used in this application.

Internal message 95.

**22:96 DRIVE OVERHEAT**

Warning: The Motor Control Unit indicates A.dOH.

Motor temperature too high. Can only be reset when motor temperature has dropped (Resistance at terminals T1/T2 > 1650  $\Omega$ ) This is indicated by message A.ndOH. See also error code 22:91.

Internal message 96.

Recommended actions:

1. Switch off the mainpower for 30 minutes until motor has cooled down.
2. Restart the machine. If problem persists, check motor windings etc.

**22:97 MOTOR PROTECTION**

Warning: The Motor Control Unit indicates A.OH2.

Electronic motor protection relay has tripped.

Internal message 97.

Recommended actions:

1. Switch off the main power to machine for 5 minutes.
2. Restart the machine.

**22:98 NO OVERLOAD**

Warning: The Motor Control Unit indicates A.nOL.

Overload counter is reset to 0%. See also message 22:99.

Internal message 98.

Recommended actions:

1. Restart the machine.

**22:99 OVERLOAD 1**

Warning: The Motor Control Unit indicates A.OL.

Overload counter has reached 100%.

The warning can only be reset after overload counter has reached 0% again. This is indicated by the message A.nOL. See also message 22:98.

Internal message 99.

Leave machine powered up without running any program for 30 minutes.

Recommended actions:

1. Check machine is not loaded more than intended.
2. Check motor and drum for mechanical fault. (jamming).
3. Check motor for electrical fault.
4. Restart the machine.

**22:100 OVERLOAD 2**

Warning: The Motor Control Unit indicates A.OL2.

Standstill constant current exceeded.

The message can only be reset after cooling time has elapsed. This is indicated by the message A.nOL2. See also message 22:101.

Internal message 100.

Recommended actions:

1. Wait until message 22:101, NO OVERLOAD 2 is shown.
2. Restart the machine.

**22:101 NO OVERLOAD 2**

Warning: The Motor Control Unit indicates A.nOL2.

Cooling time has elapsed, error over load 2 is reset. See also message 22:100.

Internal message 101.

Recommended actions:

1. Restart the machine.

**22:102 SET**

Warning: The Motor Control Unit indicates error A.SET.

It has been attempted to access a locked parameter set.

Internal message 102.

Recommended actions:

1. Upgrade machine software to latest version.
2. Restart the machine.



## DRUM MOTOR OBIWAN

### 23:1 HEATSINK TOO HOT

This error code is generated by the MCU for drum motor.

There is a temperature sensor (NTC) mounted on the MCU cooling flange next to the power transistors in the output stage. If the temperature of the cooling flange gets too high ( $> 100^{\circ}\text{C}$ ) the error code will be set to protect the transistors.

The cause of high cooling flange temperature can be e.g. a stiff drum in combination with intensive use and high ambient temperature. There may also be an error in the motor (sticking bearings or short circuit in windings, which impairs the efficiency of the motor). When temperature has decreased below  $85^{\circ}\text{C}$ , the error can be reset on the selector button.

Recommended actions:

1. Make sure the drum turns easily.
2. Check the value on the error code counter for the error code.
3. Check the last 8 MCU error codes.
4. Start a  $90^{\circ}\text{C}$  normal program with load on continuous operation and measure the temperature of the motor and MCU.
5. Replace the defective part.

### 23:2 MOTOR TOO HOT

This error code is generated by the MCU for the drum motor.

The MCU monitors the motor temperature in two ways.

1. The MCU calculates the motor winding resistance by measuring current and voltage. The winding resistance can then be converted to a temperature, since the winding resistance at  $20^{\circ}\text{C}$  and the temperature coefficient are known. If the average value of the four latest temperature readings is higher than the maximum motor temperature (e.g.  $130^{\circ}\text{C}$ ), the error code will be shown. When temperature has decreased below  $130^{\circ}\text{C}$ , the error can be reset on the selector button.
2. The MCU monitors the input from motor over heat protection. If this input is open circuit, the error will be shown. When input is closed again, the error can be reset on the selector button.

Possible causes:

The cause of high motor temperature can be a stiff drum, possibly in combination with intensive use and high ambient temperature. There may also be an error in the motor (sticking bearings or short circuit in windings, which impairs the efficiency of the motor). There could also be a contact error in the connectors between the MCU and the motor or an error in the motor cable. An error in MCU temperature measurement circuits can also occur.

Recommended actions:

- Make sure the drum turns easily.
- Check the status of motor over heat protection.
- Check the value on the error code counter for the error code.
- Check the last 8 MCU error codes.
- Measure the three phases to the phase resistors on the MCU motor connector (disconnect MCU and take the reading in the cable connector) to make sure they are the same.
- Start a  $90^{\circ}\text{C}$  normal program with load on continuous operation and measure the temperature of the motor and MCU.
- Replace the defective part.

### 23:3 NO INTERLOCK

This error code is generated by the MCU for drum motor.

The MCU must be powered with 230V / 50 or 60 Hz on the interlock input in order to drive the motor. This signal is a confirmation that the door is closed and locked.

MCU receives its commands to rotate the drum from the CPU via a serial communication link between the MCU and CPU. Since the CPU also has access to the interlock signal, the CPU must never send a run command to the MCU if the interlock signal is missing. If this does happen, this error code will be shown.

Possible causes:

The cause of this error code being activated can be e.g. a break in the cable leading the interlock signal to the MCU. There may also be an error in the connector in the door lock, which connects 230V / 50 Hz to the interlock signal. An error in the interlock circuits of the MCU can also set this error code.

Recommended actions:

1. Use a multimeter to check that there is 230V present on the MCU Interlock input when the door lock is activated. Read also bit 1 in the second byte under `MCU STATUS` in the service program (the bits are numbered from 0 to 7 where bit 0 is on the far right). If bit 1 in the second byte is 1 then the lock is open, while a 0 indicates that the lock is closed.
2. Replace the defective part.

### 23:4 NO COMMUNICATION

This error code is generated by the MCU for drum motor.

MCU detects there is there is a problem in communication with CPU.

Possible causes:

Bad contact in harness or connectors between CPU and MCU.

Recommended actions:

1. Check wiring, connections between CPU and MCU.

### 23:5 MOTOR SHORT CIRCUIT

This error code is generated by the MCU for drum motor.

The MCU reads the power consumption of the motor continuously. If the current for some reason exceeds a predetermined limit, the MCU will cut the current to the motor, and the error code will be shown.

Possible causes:

This error code can be activated for a number of reasons:

- Short circuit in motor. Measure motor windings with a Motor Tester.
- Short circuit internally in motor winding (impaired efficiency, higher current consumption).
- Short circuit in motor cables.
- Short circuit in connectors.
- Drops of water causing short circuits in the motor connector.
- Short circuit in the MCU output transistors.
- Bad contact in interlock signal.

Recommended actions:

1. If the error is a stable one, it is generally not difficult to locate the defective unit through resistance measurement and testing with the service program. Measure motor windings with a Motor Tester.
2. Further information can be obtained by studying the contents of `MCU ERROR LOG 1` and `MCU ERROR LOG 2`.
3. Review following:
4. `SHORT CIRCUIT 1` (specifies how many times the current limit has been exceeded).

### 23:6 INTERLOCK HARDWARE

This error code is generated by the MCU for drum motor.

The MCU must be powered with 230V / 50 or 60 Hz on the interlock input in order to drive the motor. The interlock circuits in the MCU have been split into two channels so that a component error in MCU cannot give a false confirmation that the door is locked. These two channels are checked against each other. If this check gives an incorrect result this error code will be shown.

Possible cause:

The reason for this error code being activated can be attributed to an error in the interlock circuits in motor control.

Recommended actions:

1. Replace MCU.

### 23:7 LOW DC VOLTAGE

This error code is generated by the MCU for drum motor.

The MCU constantly measures the voltage over the mains input. If the voltage drops below a predefined limit, the MCU will shut off the current to the motor and the error code will be shown.

The error can be reset by pressing selector button when voltage is within range again.

The reason for this error code being activated can be low mains voltage or that the machine's on/off switch has been operated in an unsuitable manner. Further information can be obtained by studying the contents of MCU ERROR LOG 1 and MCU ERROR LOG 2:

- UNDERVOLTAGE 1 (specifies how many times the voltage has dropped below the limit).
- LAST FAULT CODE N/8 (shows the 8 latest error codes) Undervoltages can be registered even during normal operation. Consequently, a small number of registrations need not mean that there is an error in the MCU.

Recommended action:

1. Check that the supply voltage is stable and never drops below nominal voltage - 10%.
2. Check the fuses and cables.
3. Check the supply voltage in the network cabling and at the MCU in the machine.

### 23:8 HIGH DC VOLTAGE

This error code is generated by the MCU for drum motor.

The MCU constantly measures the voltage over the mains input. If the voltage exceeds a predefined limit, the MCU will shut off the current to the motor, and the error code will be shown.

The error can be reset by pressing selector button when voltage is within range again.

Possible causes:

Fluctuating mains voltage.

Recommended action::

1. Check that the supply voltage is stable and never exceeds nominal voltage + 6%.

### 23:12 NO PARAMET. SET IN MCU

This error code is generated by the MCU for drum motor.

The MCU contains several different parameter sets for different motors. During power up the control system checks that the correct parameter set digit is written into the MCU. If not, the control system will write down the parameter set digit defined in fixed configuration.

If the MCU discovers that no parameter set value is written down into the MCU, the error code will be shown.

Possible causes:

This can be caused by wrong software in CPU or wrong MCU for the current machine.

Recommended actions:

1. Make sure correct machine software and correct MCU are used.

### 23:13 UNBALANCE

This error code is generated by the MCU for drum motor.

The MCU monitors the unbalance switch status. If the status is active already at program start, this error code is shown.

### 23:15 MOTOR NOT FOLLOW

This error code is generated by the MCU. The MCU continuously estimates the motor speed. If the estimated speed is less than 180 rpm 10 seconds after drive command, or higher than 180 rpm 60 seconds after stop command, the error will be shown.

Possible causes:

- Break in one of the phases to the motor (cables or connectors). This error can be suspected if the motor does not rotate for 10 seconds (the motor will not start with only two phases).
- Check that the drum can be rotated easily.
- Check motor windings for open circuit using a Motor tester.

Further information can be obtained by studying the contents of `MCU ERROR LOG 1` and `MCU ERROR LOG 2`. Study the following:

- `MOTOR NOT FOLLOW` (specifies how many times this error code has occurred).
- `LAST ERROR CODE N/8` (shows the 8 latest error codes).

Recommended action:

1. Replace the defective part.

### 23:255 UNDEFINED ERROR

This error code is generated by the MCU. The MCU reports an error that is not defined.

### FAN MOTOR COMMON

#### 30:1 O.H. FAN MOTOR

This error code will be shown if the control system detects that the input OH FAN MOTOR is deactivated during program run.

The overheating protection is automatically restored. When the overheating protection is restored the error code is automatically reset and the ongoing program will continue. A long press on the control knob/start button will make the control system reset and the ongoing program will be ended.

The error code can be triggered if:

- The motor is very warm. Check that the vent holes in the motor are not covered.

If the overheating protection is not triggered, but there is still an error code:

- Check the harness, connectors and functions by reading the electrical schematic and by using the `SHOW INPUTS` menu when the machine is in service mode.

## INTERNAL COM.

### 40:1–40:10 I/O INTERLOCK Axxx

This error code will be shown if the control system detects that the input IO INTERLOCK is not active. I/O unit designation, Axxx, that is shown in the error description is according to electric schematics and electrical component list.

Recommended actions:

1. Check that door is actually locked.
2. Check DLCU status in service mode for more information on possible causes.
3. Check P-bus connectors on I/O board for present interlock signal.
4. Check that D-bus connector is fitted correctly with regards to the rib on the connector and the slot in the plastic cover of the I/O board.

### 40:11–40:20 I/O COMMUNICATION Axxx

The error code is shown if the control system can not communicate with one or several I/O units on D-bus. I/O unit designation, Axxx, that is shown in the error description is according to electric schematics and electrical component list. Errors are related to the D-Bus communication port between CPU and the different I/O units in the machine. The error code is shown if the control system has lost communication with one or more I/O units for a certain time.

If there is communication between the I/O unit and control system the LED next to the service button will flash.

If there is no communication to the I/O unit but power, the LED will light when the button is pressed on the I/O board (all I/O boards except for I/O unit type 6).

Possible causes:

- Mistake when configuring I/O unit address at set up. Button on wrong I/O unit pressed during config.
- Two or more I/O units have the same I/O addressing.
- Bad or intermittent contact in D-Bus wiring between I/O units and CPU or between I/O units.
- Squeezed or shorted D-bus cables (shorted to ground).
- An old version of an I/O unit is fitted in the machine that do not support Compass Pro. Check part number compared to original I/O board or spare parts list.

Recommended actions:

1. Check that all I/O units are configured in I/O CONFIGURATION menu when the machine is in service mode. Alternatively use Common Service Tool to get a overview of the I/O unit configuration. Use the electric schematic to find correct I/O board to address.
2. If all I/O units are present in the list, check the LED as above, harness, connectors and functions by reading the electrical schematic.
3. Check that the I/O units fitted in the machine supports Compass Pro. Check part number compared to original I/O board or spare parts list.
4. Update the machine software to latest available version.

### 40:21 I/O COMMUNICATION

Only on Barrier washer.

The error code is activated if the control system no longer can communicate with Barrier I/O unit or if the communication is intermittent. I/O unit designation that is shown in the error description is according to electric schematics and electrical component list.

Barrier I/O board is connected to M-COM port on CPU in paralell with the MCU for drum. Electrical interface is RS-485. The error code is shown if the control system has lost or only have intermittent communication with the I/O unit.

Possible causes:

- Bad contact in harness or connectors between CPU/MCU and I/O unit.
- The I/O board is incorrectly configured on DIP switches (SW210 and SW202)

Recommended actions:

1. Check wiring, connections configuration of I/O unit according to service manual.

**40:22 I/O BOARD MISHMASH**

The error code is shown if wrong Type of I/O unit is fitted.

Could also occur if addressing of the I/O units is made in a incorrect way.

After addressing of I/O units the CPU reads the Type of each unit.

If there is a mismatch between what the Type of I/O unit the CPU finds, and what the I/O unit type the software configuration expects, the error will be shown.

Machine will not run until problem is solved. There are two exceptions: I/O type 1 can be used when I/O type 11 is expected, but not oposite. I/O type 8 can be used when I/O type 81 is expected, but not oposite.

Possible causes:

- When addressing the I/O units the operator has pressed a the button on the wrong I/O unit.
- Wrong type of I/O unit if fitted in the machine.
- Two I/O units have got the same adress.

Recommended actions:

1. Readdress all I/O units.

Use I/O CONFIGURATION function in service mode.

Alternatively use Common Service Tool, I/O addressing function.

2. Use the electric schematic to find correct I/O board to address.
3. Use Common Service Tool, I/O addressing function to get best overview/visualization of the problem.



**PLATON SERVICE**  
8 (800) 500-34-41  
www.platonservice.com

## INTERNAL COM. I/O TYPE 10

### 41:1 CHARGE CIRCUIT

The DLCU on I/O board type 10 contains an arming circuit that is charged when the door lock coil is to be activated. For safety reasons, this arming circuit must be discharged when the door lock coil is not to be activated. If the arming circuit for operating the door lock is charged when it is not supposed to be, an error message will be sent to the CPU. CPU reads the error message when the door is locked and unlocked and generates an error. The error is ignored between these two occasions.

Possible causes:

- The error can be caused by overloads and/or defective components in the DLCU on I/O board type 10.

For pocket machine, this error relates to I/O board type 10 on "Loading side".

See also corresponding error 41:21 for I/O type 10 on "Unloading side".

### 41:2 SET SIGNAL NO TACHO. WAIT 5 MINUTES

The DLCU on I/O board type 10 counts the tacho pulses from the motor in order to guarantee that the drum is standing still before the door is opened. To ensure that the signal from the tacho generator is working correctly, DLCU compares the tacho signal with a digital bit value from the CPU, which is due to the CPU having activated the motor (See DLCU status indication).

Error will reset automatically after 5 minutes and door will then unlock. The error message is filtered in such a way that: - the digital bit value should have been active for more than 2 seconds - when the digital bit value goes low, tacho signal must be present - test is only performed when door is about to unlock.

Possible causes:

- Open or shorted circuit to the tacho sensor.
- Damaged tacho sensor or magnet.
- Secondary fault due to a error in the motor system.

Recommended actions:

1. Check that motor is actually running.
2. Check there is voltage from tachometer output when motor is running.
3. Check that rotation is detected in DLCU status for the I/O type 10 board.

For pocket machine, this error relates to I/O board type 10 on "Loading side".

See also corresponding error 41:22 for I/O type 10 on "Unloading side".

### 41:3 ACTUATOR CIRCUIT

The DLCU on I/O board type 10 continuously controls the circuit to the door lock solenoid. DLCU can detect an open circuit (>50 k $\Omega$ ) but not a short circuit.

If case of an open circuit, CPU will show the error.

The error will disappear if the error is removed.

Possible causes:

- Open circuit to the door lock solenoid.
- Open circuit in the door lock solenoid.
- Error or open circuit in the I/O board 10 circuits.

Recommended actions:

1. Check resistance in door lock solenoid circuit. Correct reading is approx. 6  $\Omega$ .
2. Check if error "AC" still remains in DLCU status.

For pocket machine, this error relates to I/O board type 10 on "Loading side".

See also corresponding error 41:23 for I/O type 10 on "Unloading side".



### 41:21 CHARGE CIRCUIT

Only on Pocket washer.

Pocket washer uses two I/O boards type 10, one for the "Loading side" and one for the "Unloading side".

This error relates to I/O board type 10 on "Unloading side".

See also corresponding error 41:1 for I/O type 10 on "Loading side".

The DLCU on I/O board type 10 contains an arming circuit that is charged when the door lock coil is to be activated. For safety reasons, this arming circuit must be discharged when the door lock coil is not to be activated. If the arming circuit for operating the door lock is charged when it is not supposed to be, an error message will be sent to the CPU. CPU reads the error message when the door is locked and unlocked and generates an error. The error is ignored between these two occasions.

Possible causes:

- The error can be caused by overloads and/or defective components in the DLCU on I/O board type 10.

### 41:22 SET SIGNAL NO TACHO. WAIT 5 MINUTES

Only on Pocket washer.

Pocket washer uses two I/O boards type 10, one for the "Loading side" and one for the "Unloading side".

This error relates to I/O board type 10 on "Unloading side".

See also corresponding error 41:2 for I/O type 10 on "Loading side".

The DLCU on I/O board type 10 counts the tacho pulses from the motor in order to guarantee that the drum is standing still before the door is opened. To ensure that the signal from the tacho generator is working correctly, DLCU compares the tacho signal with a digital bit value from the CPU, which is due to the CPU having activated the motor (See DLCU status indication).

Error will reset automatically after 5 minutes and door will then unlock.

The error message is filtered in such a way that:

- The digital bit value should have been active for more than 2 seconds.
- When the digital bit value goes low, tacho signal must be present.
- Test is only performed when door is about to unlock.

Possible causes:

- Open or shorted circuit to the tacho sensor.
- Damaged tacho sensor or magnet.
- Secondary fault due to a error in the motor system.

Recommended actions:

1. Check that motor is actually running.
2. Check there is voltage from tachometer output when motor is running.
3. Check that rotation is detected in DLCU status for the I/O type 10 board.

### 41:23 ACTUATOR CIRCUIT

Only on Pocket washer.

Pocket washer uses two I/O boards type 10, one for the "Loading side" and one for the "Unloading side".

This error relates to I/O board type 10 on "Unloading side".

See also corresponding error 41:3 for I/O type 10 on "Loading side".

The DLCU on I/O board type 10 continuously controls the circuit to the door lock solenoid. DLCU can detect an open circuit (>50 k $\Omega$ ) but not a short circuit. If case of an open circuit, CPU will show the error. The error will disappear if the error is removed.

Possible causes:

- Open circuit to the door lock solenoid.
- Open circuit in the door lock solenoid.
- Error or open circuit in the I/O board 10 circuits.

Recommended actions:

1. Check resistance in door lock solenoid circuit. Correct reading is approx. 6  $\Omega$ .
2. Check if error "AC" still remains in DLCU status.



## INTERNAL COM. I/O TYPE 6

### 42:1 I/O TYPE 6 INTERNAL ERROR

I/O unit type 6, reading of internal analog values out of range.

Possible causes:

- Intermittent error in wiring to I/O type 6 unit.
- Internal error in I/O type 6.

Recommended actions:

1. Switch power off for 1 minute and try again.
2. If problem remains, replace defective part.

### 42:2 I/O TYPE 6 POSITION TEST

Position test is used to verify that I/O type 6 unit is correctly assembled and fixed in the expected position.

Recommended actions:

1. Check that I/O type 6 unit is assembled and fixed in correct position.

### 42:3 I/O TYPE 6 EXTRACT TEST

I/O unit type 6 is not able to read any or too low values during extraction.

Recommended actions:

1. Check that I/O unit type 6 unit is assembled and fixed in correct position.
  2. Put some unbalance in drum and run motor to extraction speed in service program.
- Check analog input readings for I/O 6.

## EXTERNAL COM. PAYMENT

### 51:22 NO CBT COMMUNICATION PRESS TO RETRY

Machine connected to payment system using serial communication to machine.

Cause:

- Communication has been established once and then interrupted.

Recommended actions:

1. Check electrical connections between CPU and payment system.
2. If running in a network, check network cables between machine and payment system.
3. Check that payment system is operational.
4. Check that payment system and machine is configured to the same Machine adress (Config 1).
5. To reset machine to working state without repairing payment system, use Reset CBT communication in service mode. (Requires password).

## EXTERNAL COM. CMIS

### 52:1 CMIS COMMUNICATION ERROR

Communication between machine and CMIS computer has been interrupted.

The warning will be shown at program start for 5 seconds, the next 5 programs. It is then removed automatically.

After the warning message has disappeared the machine will start, but no CMIS data statistics/data will be logged.

Possible causes:

- If using ELS Common Service Tool process viewer and cable has been unplugged before process viewer has been stopped, this warning will occur.
- If running with ELS CMIS and communication is interrupted to PC, warning will occur.

Recommended actions:

1. If using ELS CST, reconnect, enter Process viewer and select function "Reset MIS communication".

2. If using ELS Network and CMIS:

Check ELS network cable between machine and PC.

Check that CMIS application is active and running normally.

For CMIS: The machine can operate but statistics will be affected and data will be lost.

### 52:2 DMIS COMMUNICATION ERROR

This is a warning message that will be shown for 5 seconds if there is a problem in DMIS communication, i.e. the communication between the machine and an external detergent dosing system.

Warning is shown if system has been up running once and then is interrupted or working intermittent.

The warning will be shown at program start for 5 seconds, the next 5 programs. It is then removed automatically.

After the warning message has disappeared the machine will start, but there is a risk the wash will run without any external detergent dosing.

Possible causes:

- The external dosing system has been disconnected, switched off or broken.
- Machine address in machine has been changed and this is also used by external dosing system.

Recommended actions:

1. Check connections, cables or network between machine and detergent dosing system.

2. Consult the supplier for external dosing system.

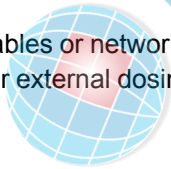

## INTERNAL

### 60:5 FATAL ERROR INVALID RUNNING MODE

The control system has an internal error during memory read.

Recommended actions:

1. Press the control knob/start button to retry.
2. If problem persists, upload new software.

### 60:11 FATAL ERROR EXTERNAL FLASH WRITE

The control system has an internal error during memory read.

Recommended actions:

1. Press the control knob/start button to retry.
2. If problem persists, upload new software.

### 60:17 FATAL ERROR INVALID OPTION

The control system has an internal error during memory read.

Recommended actions:

1. Press the control knob/start button to retry.
2. If problem persists, upload new software.

### 60:18 FATAL ERROR INVALID MODULE

The control system has an internal error during memory read.

Recommended actions:

1. Press the control knob/start button to retry.
2. If problem persists, upload new software.

### 60:28 FATAL ERROR INVALID COIN INPUT

The control system has an internal error during memory read.

Recommended actions:

1. Press the control knob/start button to retry.
2. If problem persists, upload new software.

### 60:29 FATAL ERROR INVALID FONT

The control system has an internal error during memory read.

Recommended actions:

1. Press the control knob/start button to retry.
2. If problem persists, upload new software.

## 14 Maintenance

### 14.1 Inspect the interior of the machine

Inspect the interior of the machine to ensure that no leaks are noticed.

During an actual wash cycle; disconnect the power to the machine and proceed as follows:

- Remove the top panel, the front and rear panel.
- Verify that all internal hoses do not leak.
- Check that water does not leak onto the floor.
- Inspect the belt. Adjust the tension or replace if necessary.
- If the heating time is unusually long, check the heating elements. If the water is very hard, check whether there are lime deposits on the heating elements. Decalcify the elements if necessary. Adapt the amount of deliming agent to the manufacturer's guidelines.
- Never switch on the heating elements when there is no water in the machine. This will cause the thermal fuse to trigger.
- Inspect the shock absorbers and coil springs.



PLATON SERVICE

8 (800) 500-34-41

[www.platonservice.com](http://www.platonservice.com)



**PLATON**SERVICE

8 (800) 500-34-47

[www.platonservice.com](http://www.platonservice.com)



Electrolux Laundry Systems Sweden AB  
341 80 Ljungby, Sweden  
[www.electrolux.com/professional](http://www.electrolux.com/professional)

Share more of our thinking at [www.electrolux.com](http://www.electrolux.com)